

CIMC ISO DRY CONTAINER REPAIRING SPARE PARTS CATALOG

2023 Edition



CIMC

FRICSA/ASCOSEL

Dirección: Viveros de Asís No. 293 Colonia Viveros de la Loma Tlalnepantla
Estado de México. C.P. 54080

Tel: (52) 5563484288 (Móvil) (52) 5553613165 (Ofna Mx) (52) 3141202056
(Ofna Manzanillo Colima)

E-mail : fausto.rivera@yahoo.com & smd_sandra@hotmail.com



CIMC ISO DRY CONTAINER REPAIRING PART CATALOG

2018

NO.	ITEM	PART NO.	SPEC&SIZE	OTHER	PAGE			
1	Roof Panel	CIMC-D01-01	2.0X1045X2356	5 Corr.	1			
		CIMC-D01-05	2.0X1045X600	5 Corr. Patch				
		CIMC-D01-05-2	2.0X1045X1200	5 Corr.				
		CIMC-D01-09	2.0X1045X2356	4 Corr.	2			
		CIMC-D01-05-3	2.0X1045X600	4 Corr. Patch				
		CIMC-D01-05-4	2.0X1045X1200	4 Corr.	3			
		CIMC-D01-03	2.0X1045X2356	Textainer				
		CIMC-D01-07	2.0X1045X600	Textainer Patch				
		CIMC-D01-04	2.0X1144X2359	Evergreen	4			
		CIMC-D01-08	2.0X1144X600	Evergreen Patch				
2	Side Panel	CIMC-D02-01A	1.6X1116X2400	Standard	5			
		CIMC-D02-01B	1.6X1116X2700	Standard				
		CIMC-D02-01C	2.0X1116X2400	Standard				
		CIMC-D02-01D	2.0X1116X2700	Standard				
		CIMC-D02-04A-1	1.6X1016X2400	HanJin				
		CIMC-D02-04B-1	1.6X1016X2700	HanJin				
		CIMC-D02-05A	2.0X1142X2400	Wide Flange				
		CIMC-D02-05B	2.0X1142X2700	Wide Flange				
		CIMC-D02-02A	Patch: 1.6X278X150	1 Corr.	6			
		CIMC-D02-02B	Patch: 1.6X278X300	1 Corr.				
		CIMC-D02-02C	Patch: 1.6X556X150	2 Corr.				
		CIMC-D02-02D	Patch: 1.6X556X300	2 Corr.				
		CIMC-D02-02E	Patch: 1.6X556X600	2 Corr.				
		CIMC-D02-02F	Patch: 1.6X1116X300	4 Corr.				
		CIMC-D02-02G	Patch: 1.6X1116X600	4 Corr.				
		CIMC-D02-02H	Patch: 1.6X1116X1200	4 Corr.				
		3	Front End Panel	CIMC-D03-01A		2.0X1024X2400	4 Corr.	7
				CIMC-D03-01B		2.0X1024X2700	4 Corr.	
CIMC-D03-02A	2.0X1024X2400			Evergreen,5 Corr.				
CIMC-D03-02B	2.0X1024X2700			Evergreen,5 Corr.				
CIMC-D03-03	Patch: 2.0X256X2700			1 Corr.	8			
CIMC-D03-04	Patch: 2.0X546X2700			2 Corr.				
CIMC-D03-05	Patch: 2.0X796X2700			3 Corr.				
4	Door Panel	CIMC-D04-01A	2.0X943X1957	20'&40', 2 Corr.	9			
		CIMC-D04-01B	2.0X943X2262	40'HC, 2 Corr.				
		CIMC-D04-02A	2.0X943X1957	20'&40', 3 Corr.				
		CIMC-D04-02B	2.0X943X2262	40'HC, 3 Corr.				
		CIMC-D04-03A	2.0X943X1957	20'&40', 4 Corr.				
		CIMC-D04-03B	2.0X943X2262	40'HC, 4 Corr.				
5	Front Corner Post	CIMC-D05-01A	6.0X209X225X2400	Standard	10			
		CIMC-D05-01B	6.0X209X225X2700					
		CIMC-D05-02A	6.0X229X245X2400	Wide Flange				
		CIMC-D05-02B-1	6.0X229X245X2700					
		CIMC-D05-02B-1	6.0X229X245X2725					
		CIMC-D05-03A	6.0X229X214X2420					
		CIMC-D05-03B	6.0X229X214X2743					

NO.	ITEM	PART NO.	SPEC&SIZE	OTHER	PAGE
5	Front Corner Post	CIMC-D05-03C	6.0X229X214X2700		10
		CIMC-D05-06B	6.0X248X232X2700		
		CIMC-D05-07A	6.0X246X231X2420		
		CIMC-D05-07B	6.0X246X231X2743		
	Front Corner Post with Reinforcement Inside	CIMC-D05-05A	6.0X209X225X2420 & 3.2X207X2420		11
		CIMC-D05-05B	6.0X209X225X2720 & 3.2X207X2720		
6	Rear Corner Post, Outer	CIMC-D06-01A	6.0X50X40X230X2400	Standard	12
		CIMC-D06-01B	6.0X50X40X230X2700		
		CIMC-D06-02A	6.0X70X40X230X2400	Wide Flange	
		CIMC-D06-02B	6.0X70X40X230X2700		
	Rear Corner Post, Inner	CIMC-D06-03B	12X113X40X2353		
		CIMC-D06-03C	12X113X40X2657		
	Rear Corner Post	CIMC-D06-04B	CIMC-D06-01A & CIMC-D06-03B		
		CIMC-D06-04C	CIMC-D06-01B & CIMC-D06-03C		
CIMC-D06-05A		CIMC-D06-02A & CIMC-D06-03B			
CIMC-D06-05B		CIMC-D06-02B & CIMC-D06-03C			
7	Cross Member	CIMC-D07	TXAXBXCXL		13
8	Bottom Side Rail	CIMC-D08-01C	4.5X50X162X30X5702	C Type	14
		CIMC-D08-02	4.5X50X155X30X5702	Double Z	
9	Top Side Rail	CIMC-D09-01A	3.0X60X60X5702	Square Tube	15
		CIMC-D09-02C	14X50X5702	Flat Bar	
		CIMC-D09-03	T=4.0 L=2400 "U" Type	Maersk	16
		CIMC-D09-04	T=4.0 L=2400 "W" Type		
10	Door Sill	CIMC-D10-01	4.5X158X150X2400		17
		CIMC-D10-01-4	4.0X158X150X2400		
	"C" Channel	CIMC-D10-03	9.0X200X75X70		18
	"V" Channel	CIMC-D10-04	10.0X300X95X70		
11	Front Bottom Rail	CIMC-D11-01	4.5X115X154X2400	Standard	19
		CIMC-D11-01-11	4.5X115X154X2400		
12	Top End Rail	CIMC-D12-01	3.0X100X26X277X2400	20'	20
		CIMC-D12-02	3.0X121X26X194X2400	40'/40'HC	
		CIMC-D12-03	4.0X95X26X304.8X2420	Extension Plate	
13	Door Header Upper	CIMC-D13-01	3.0X394X2400	20'	21
		CIMC-D13-02	3.0X346X2400	40'/40'HC	
	Door Header Lower	CIMC-D13-03	4.0X112X113X137X2400		
14	Door Rail	CIMC-D14-01	4.0X50X150X50X943		22
15	Floor Spacer	CIMC-D15-01	2.3X42X28X25X3000		
16	Angle	CIMC-D16	4.5/6.0/4.0XAXBX2400		23
17	Top / Bottom End Rail	CIMC-D17-01A	3.0X60X60X2112	Square Tube	24
18	Door Edge Member	CIMC-D18-01A	3.2X50X100X2248	20'&40'	
		CIMC-D18-01B	3.2X50X100X2552	40'HC	
19	Corner Casting	CIMC-D19-01	178X162X118	Set, 8pcs/Set	25
		CIMC-D19-01-1	178X162X118	BL	
		CIMC-D19-01-2	178X162X118	BR	
		CIMC-D19-01-3	178X162X118	TL	
		CIMC-D19-01-4	178X162X118	TR	
		CIMC-D19-02	178X193X118	45' Width	
		CIMC-D19-03	247X180X118	45' Standard	

NO.	ITEM	PART NO.	SPEC&SIZE	OTHER	PAGE	
20	Stainless Steel Door Seal Retainer Strip	CIMC-D20-01A	1.0X23X7X1130		26	
		CIMC-D20-01B	1.0X23X7X2249	20'&40'		
		CIMC-D20-01C	1.0X23X7X2549	40'HC		
	ABS Door Seal Retainer Strip	CIMC-D20-03A	2.0X32X9X1142		27	
CIMC-D20-03B		2.0X32X9X2242	20'&40'			
21	Sealant	CIMC-D21-01	Neoprene (Grey)	310ml/pcs, 30pcs/pkg	28	
		CIMC-D21-02	Neoprene (Black/White)			
		CIMC-D21-03	Butyl (Grey)			
		CIMC-D21-04	Butyl (Black)			
		CIMC-D21-05	Silicone Sealant (White)			
22	Cam	CIMC-D23-01A	L.H		29	
		CIMC-D23-01B	R.H			
		CIMC-D23-01C	Security Cam R.H			
		CIMC-D23-01D	Security Cam L.H.			
		CIMC-D23-01G	Security Cam with Hole R.H			Maersk
	Keeper	CIMC-D23-02A	L.H	For Corrugated Door	31	
		CIMC-D23-02B	R.H	For Corrugated Door		
		CIMC-D23-02C	L.H.	For Flat Door		
		CIMC-D23-02D	R.H.	For Flat Door		
		CIMC-D23-02E	Security Keeper R.H.		32	
		CIMC-D23-02F	Security Keeper L.H.			
	CIMC-D23-02G	Security Keeper with hole R.H.	Maersk	33		
	Bearing Bracket	CIMC-D23-03	Outer L		34	
		CIMC-D23-04	Inner L			
		CIMC-D23-05	Outer S			35
		CIMC-D23-06	Inner S			
	Handle	CIMC-D23-07A	Forging Type		36	
		CIMC-D23-07B	Press Type			
		CIMC-D23-07C	Without Hole			
		CIMC-D23-07E	ET Security Type			37
	Retainer Catch	CIMC-D23-08A	Forging Type		38	
		CIMC-D23-08B	Press Type			
		CIMC-D23-08C	Without Hole			
	Retainer Plate	CIMC-D23-09A	Forging Type		39	
		CIMC-D23-09B	Press Type			
CIMC-D23-09C		Without Hole				
Bush	CIMC-D23-10			40		
Handle Hub	CIMC-D23-11					
Rivet	CIMC-D23-12					
Anti - Rack Ring	CIMC-D23-13					
ET Handle Hub	CIMC-D23-11E	ET Security Type			41	
ET Rivet	CIMC-D23-12E	ET Security Type		42		
Upper Short Split Bush	CIMC-D23-14					
Lower Short Split Bush	CIMC-D23-15					
Split Large Bush	CIMC-D23-16	Pair				
Split Small Bush	CIMC-D23-17	Pair				
23	Hinge Blade	CIMC-D24-01	Forging Type		43	
		CIMC-D24-02	Welding Type			

NO.	ITEM	PART NO.	SPEC&SIZE	OTHER	PAGE
23	Hinge Blade	CIMC-D24-03	Welding Type		43
		CIMC-D24-04	Maersk	Maersk	
	Hinge Pin	CIMC-D24-05	L=108mm		44
		CIMC-D24-05-1	L=139mm		
		CIMC-D24-05-2	L=94mm		
	Hinge Lug	CIMC-D24-06	T=9mm		
	Brass Wash	CIMC-D24-07			
	Bracket Gasket	CIMC-DGE06	T=1.0		Use for BBOL
		CIMC-DGE07040	T=1.0		Use for BBOS
CIMC-DGE08040		T=1.0		Use for Retainer Plate	
24	Lock Box	CIMC-D24-10			45
25	Ventilator	CIMC-D25-01	"S" Type		46
		CIMC-D25-02	"M" Type		47
		CIMC-D25-03	TAL		48
		CIMC-D25-04	For Pallet Wide		49
26	Door Seal	CIMC-D26-01A	Container Set, 20'/40'	"JC" Type	50
		CIMC-D26-01B	Container Set, 40'HC	"JC" Type	
		CIMC-D26-02A	Container Set, 20'/40'	"C" Type	
		CIMC-D26-02B	Container Set, 40'HC	"C" Type	51
		CIMC-D26-02C	2.50M/ PC	"C" Type	
		CIMC-D26-02D	40.00M / Roll	"C" Type	
		CIMC-D26-02E	300mmX300mm	"C" Type	
		CIMC-D26-03A	Container Set, 20'/40'	"J" Type	52
		CIMC-D26-03B	Container Set, 40'HC	"J" Type	
		CIMC-D26-03C	2.50Mtrs / PC	"J" Type	
		CIMC-D26-03D	300mmX300mm	"J" Type	
		CIMC-D26-03K	1200mmX1200mm	"J" Type	
		27	Door Screw	CIMC-D27-01	M10X25
CIMC-D27-02	M10X35				
Door Screw Nut	CIMC-D27-03		M10		
Door Screw Rubber	CIMC-D27-04		Φ10		
28	Tapping Screw	CIMC-D28-01A	M6X45	Cross Groove	54
		CIMC-D28-01B	M6X65	Cross Groove	
		CIMC-D28-02A	M8X45	Cross Groove	
		CIMC-D28-02B	M8X50	Cross Groove	
		CIMC-D28-02C	M8X65	Cross Groove	
		CIMC-D28-02A-1	M8X45	Club Groove	
		CIMC-D28-02B-1	M8X50	Club Groove	
		CIMC-D28-02C-1	M8X65	Club Groove	
29	Stainless Steel Blind Rivet	CIMC-D29-01	M4.8X7		55
		CIMC-D29-02	M4.8X14		
		CIMC-D29-03	M4.8X16.7		
30	Lashing Ring	CIMC-D30-01	Φ8X70		56
		CIMC-D30-02	Φ12X140		
		CIMC-D30-03	Φ12X64		
		CIMC-D30-05	Φ12X58		
		CIMC-D30-06	Φ6X44		
31	CSC Plate	CIMC-D31-01	0.8X100X200		57
		CIMC-D31-02	0.8X200X250		58

NO.	ITEM	PART NO.	SPEC&SIZE	OTHER	PAGE	
31	CSC Plate	CIMC-D31-03	0.8X210X270		59	
32	Wooden Flooring	CIMC-D32-01A	28X1160X2400		60	
		CIMC-D32-01B	28X640X2400			
		CIMC-D32-01C	28X1220X2440			
	Bamboo Plywood	CIMC-D32-02	28X1160X2400		61	
33	Gooseneck Cross Rail	CIMC-D33-01A	4.0X75X100X75X2268		62	
		CIMC-D33-01B	4.0X100X75X2328			
		CIMC-D33-01C	6.0X100X150X60X2328			
	Gooseneck Side Rail	CIMC-D33-02	6.0X146X65X3305		63	
	Gooseneck Bottom Rail	CIMC-D33-03	4.5X26X100X26X1029			
	Gooseneck Plate	CIMC-D33-04	4.5X150X1160X3307			
36	Tapping Screw Bit	CIMC-D36-01	Double End	Cross Groove	64	
		CIMC-D36-01-1	Simple End	Cross Groove		
		CIMC-D36-01-2	Simple End	Club Groove		
	Socket	CIMC-D36-01-3	M12.5X12.5			
		CIMC-D36-01-4	M19X19			
	Redrill Bit	CIMC-D36-02				
	Container Inspection Tools	CIMC-D36-06	Set			65
Magnetic Measuring lines	CIMC-D36-05					
Measuring Rule	CIMC-D36-06-1					
Hammer for inspection	CIMC-D36-06-2					
37	Garment Hanger Bar	CIMC-D37-01	L=2286mm		66	
		CIMC-D37-02	L=2260mm~L=2310mm		67	
38	Tir Wire Completed with End 20'	CIMC-K01-01	L=22M		68	
	Tir Wire Completed with End 40'	CIMC-K01-02	L=33M			
	Cable Seal End	CIMC-K01-03				
	Eyelet	CIMC-K01-04	Pair	Open top		
	Hinge Blade, Open Top	CIMC-K01-05	R.H. or L.H.			
	Hinge Pin with Chain, Open Top	CIMC-K01-06				69
	Tarpaulin, Raw Cloth	CIMC-K02-03	20', 3mX6.5m	610g/m ² or 650g/m ²		
	Tarpaulin, Raw Cloth	CIMC-K02-04	40', 3mX12.6m			
	Tarpaulin Welding Tape	CIMC-K02-05-3	Roll			
	Rubber Roller & Tilt Patch Gun					
Roof Bow	CIMC-K03-01	T=3.0(1.5), L=2260mm		70		
Roof Bow	CIMC-K03-02	T=3.0(1.5), L=2325mm				

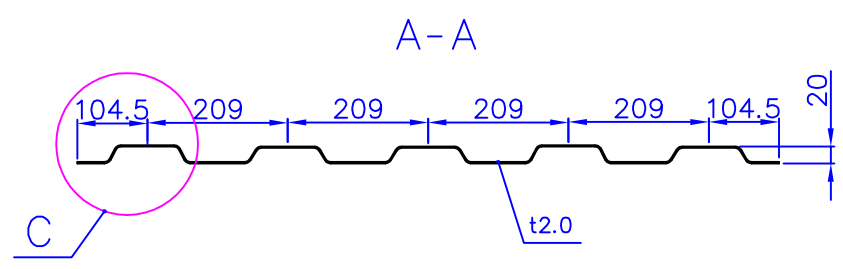
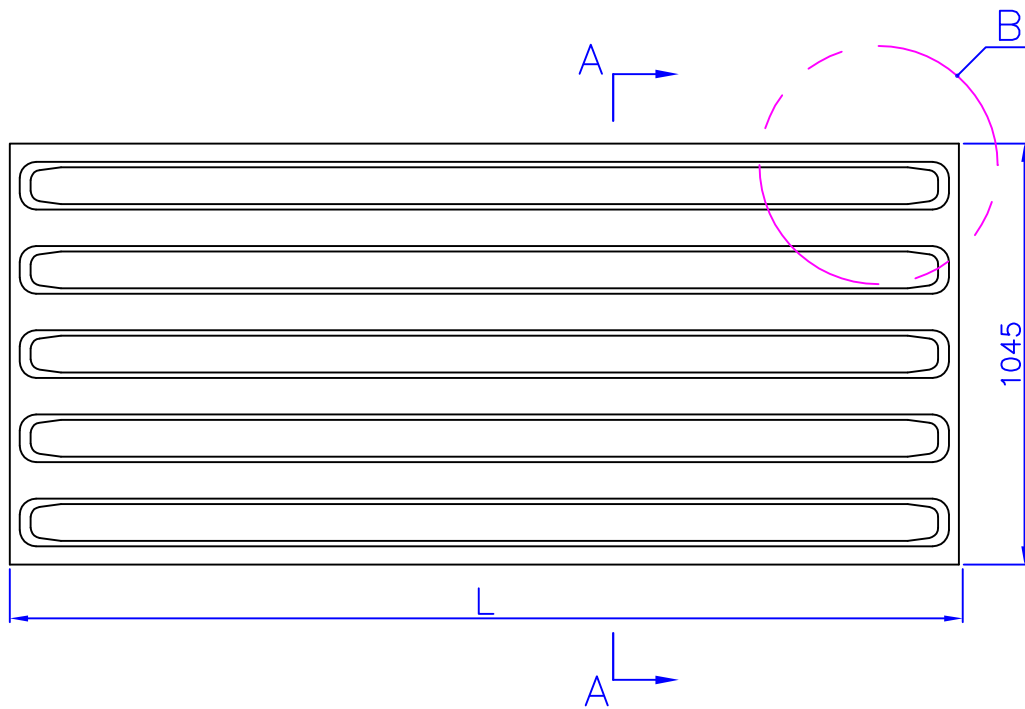

DETAIL B
2:1

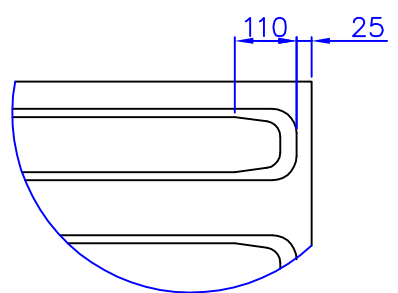

DETAIL C
2:1

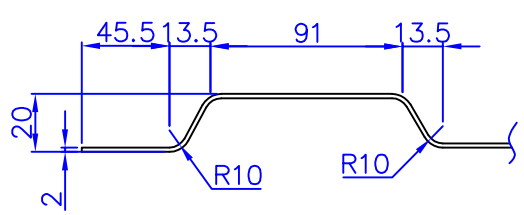

注: Corrugation depth 波深20mm,
Camber 拱度4-7mm

PART NO.	SPEC	WEIGHT
CIMC-D01-01	2.0X1045X2356	42.117
CIMC-D01-05	2.0X1045X600	11.443
CIMC-D01-05-2	2.0X1045X1200	22.088

TITLE	Roof Panel (Patch) 五波圆头大/小/中顶板	WEIGHT	KGS		
SPEC	2.0 X 1045 X L	MATERIAL	CORTEN		
PART NO.	CIMC-D01-01/05/05-2	UNIT	mm	PAGE NO.	1

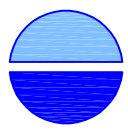

CIMC

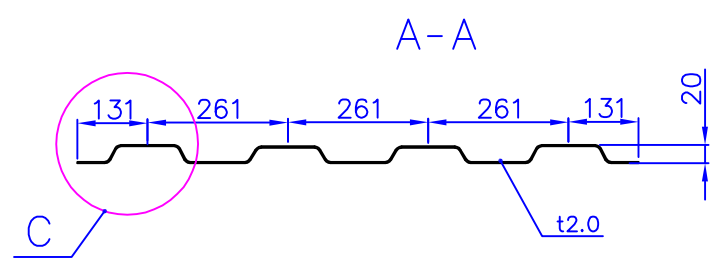
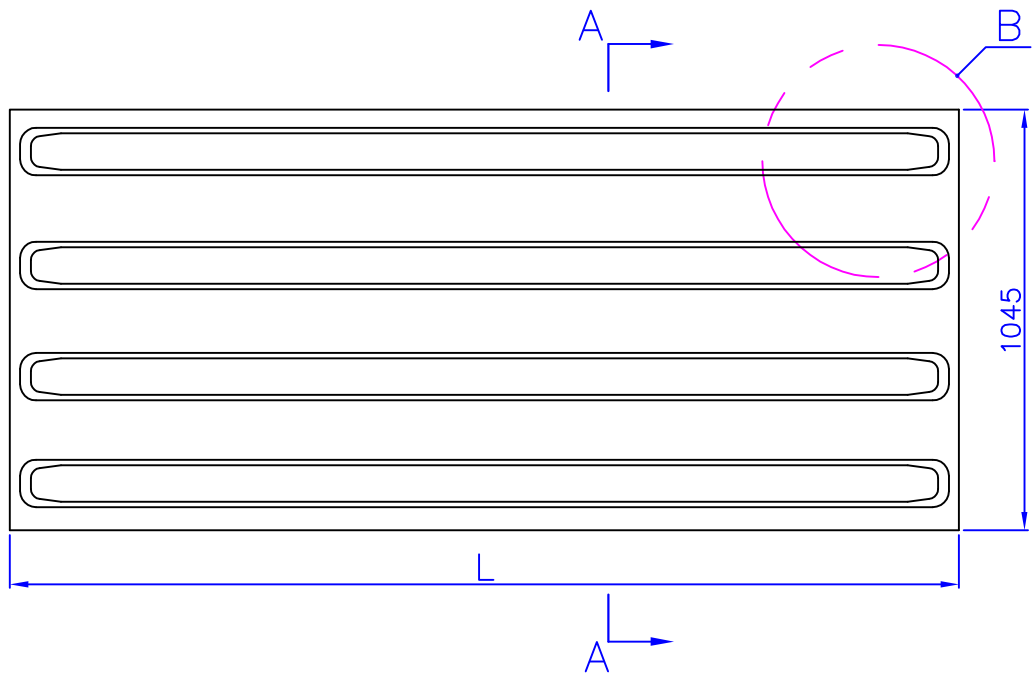

DETAIL B
2:1

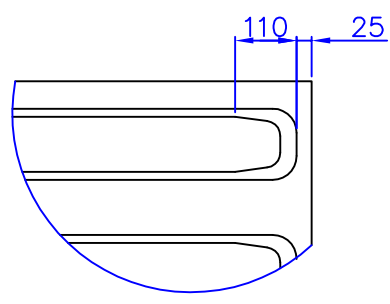

DETAIL C
2:1

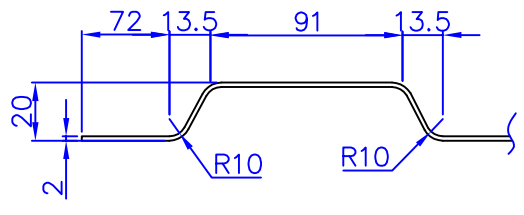

注: Corrugation depth 波深20mm,
Camber 拱度4-7mm

PART NO.	SPEC	WEIGHT
CIMC-D01-09	2.0X1045X2356	42.117
CIMC-D01-05-3	2.0X1045X600	11.443
CIMC-D01-05-4	2.0X1045X1200	22.088

TITLE	Roof Panel (Patch) 四波圆头大/小/中顶板	WEIGHT	KGS		
SPEC	2.0 X 1045 X L	MATERIAL	CORTEN		
PART NO.	CIMC-D01-09/05-3/05-4	UNIT	mm	PAGE NO.	2



CIMC

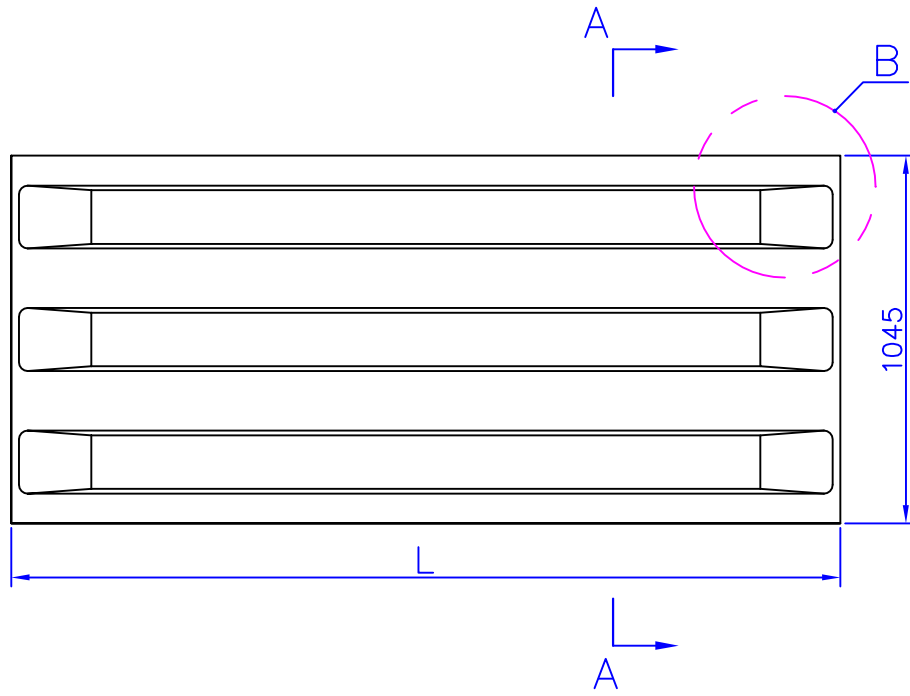

A-A

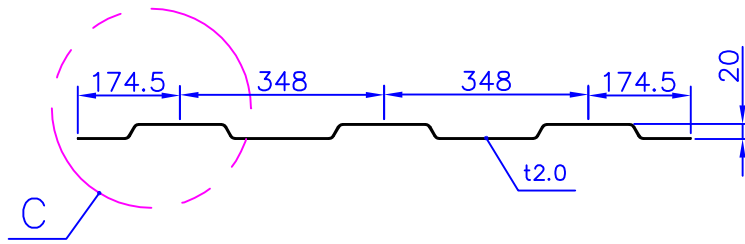

DETAIL B
2:1

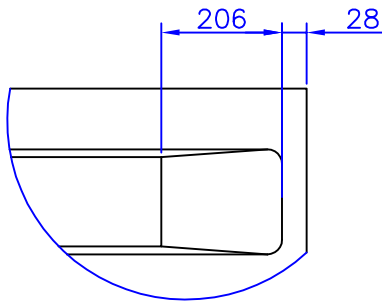

DETAIL C
2:1

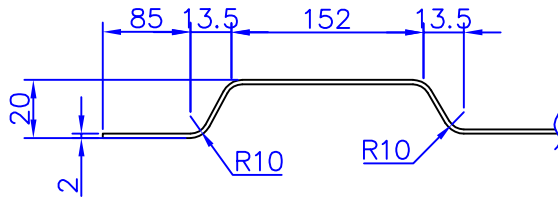

注: Corrugation depth 波深20mm,
Camber 拱度4-7mm

PART NO.	SPEC	WEIGHT
CIMC-D01-03	2.0X1045X2356	41.476
CIMC-D01-07	2.0X1045X600	11.240

TITLE	Roof Panel (Patch) 三波方头大/小顶板	WEIGHT	KGS		
SPEC	2.0 X 1045 X L	MATERIAL	CORTEN		
PART NO.	CIMC-D01-03/07	UNIT	mm	PAGE NO.	3

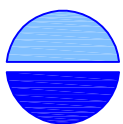

CIMC

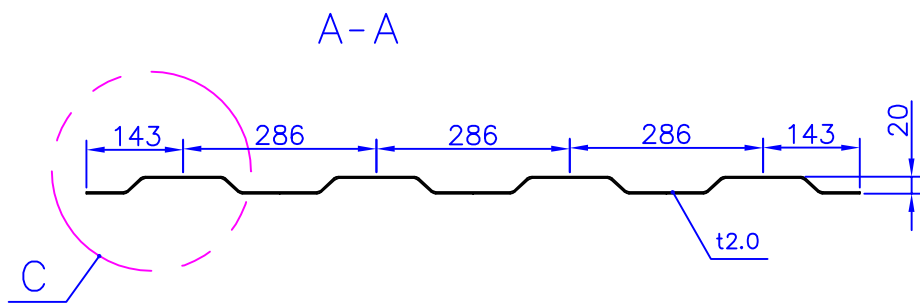
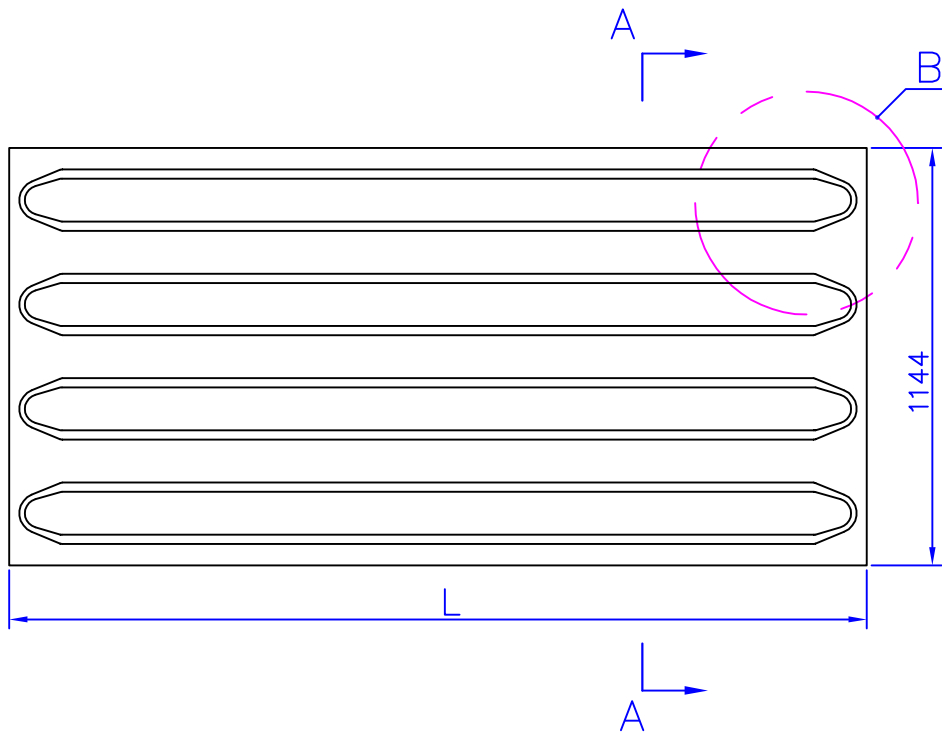

DETAIL B
2:1

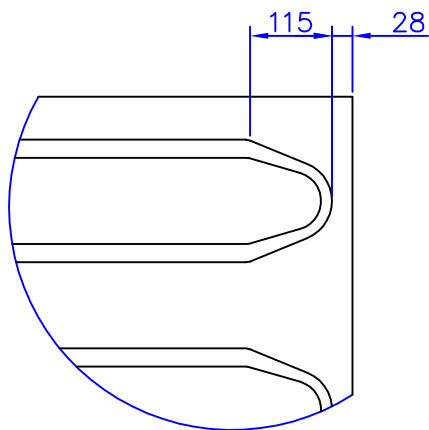

DETAIL C
2:1

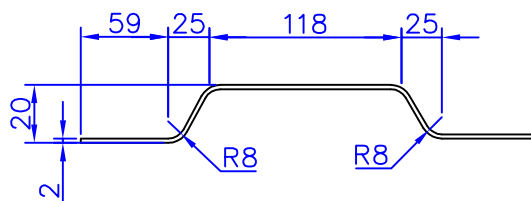

注: Corrugation depth 波深20mm,
Camber 拱度4-7mm

PART NO.	SPEC	WEIGHT
CIMC-D01-04	2.0X1144X2359	46.158
CIMC-D01-08	2.0X1144X600	12.501

TITLE	Roof Panel (Patch) 四波尖头大/小顶板	WEIGHT	KGS		
SPEC	2.0 X 1045 X L	MATERIAL	CORTEN		
PART NO.	CIMC-D01-04/08	UNIT	mm	PAGE NO.	4

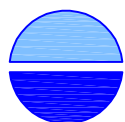

CIMC

Side Panel 侧板

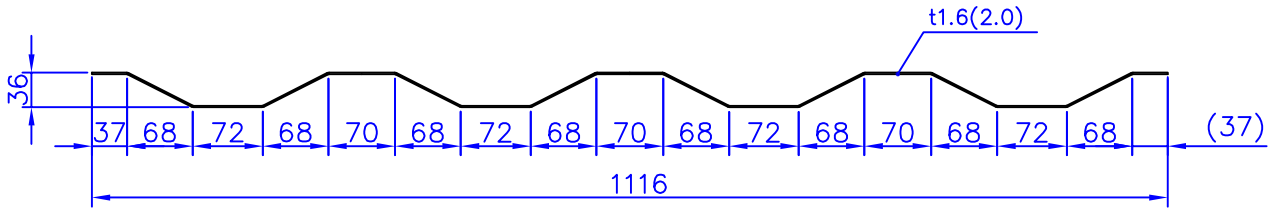

PART NO.	SPEC	WEIGHT
CIMC-D02-01A	1.6X1116X2400	35.721
CIMC-D02-01B	1.6X1116X2700	40.186
CIMC-D02-01C	2.0X1116X2400	44.462
CIMC-D02-01D	2.0X1116X2700	50.020

Side Panel 超宽侧板

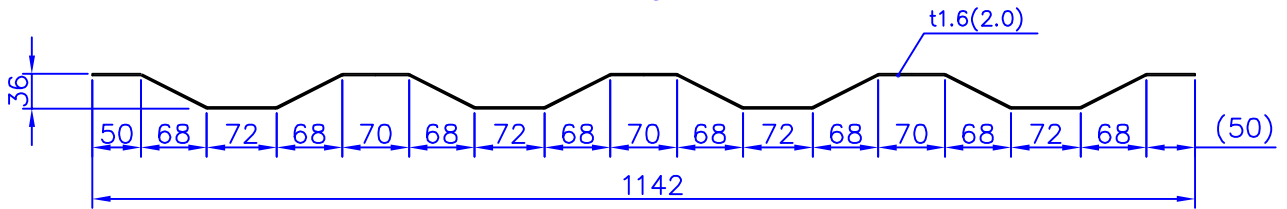

PART NO.	SPEC	WEIGHT
CIMC-D02-05A	2.0X1142X2400	47.097
CIMC-D02-05A-1	2.0X1142X2380	46.704
CIMC-D02-05A-2	1.6X1142X2380	37.363
CIMC-D02-05B	2.0X1142X2700	52.984
CIMC-D02-05B-1	2.0X1142X2743	53.828
CIMC-D02-05B-2	1.6X1142X2743	43.062
CIMC-D02-05B-3	1.6X1142X2700	42.387

HANJIN Side Panel 韩进侧板

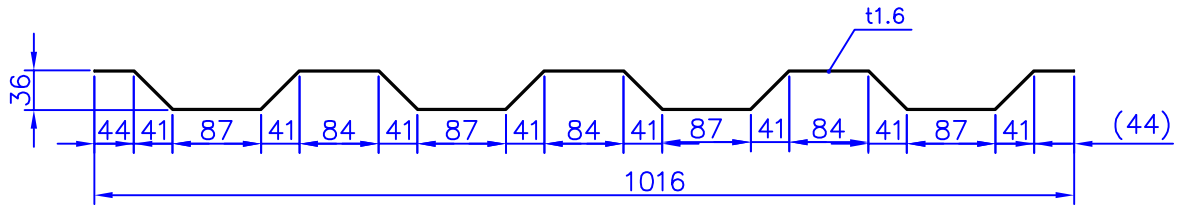

PART NO.	SPEC	WEIGHT
CIMC-D02-04A-1	1.6X1016X2400	32.915
CIMC-D02-04B-1	1.6X1016X2700	37.029

TITLE	Side Panel 侧板	WEIGHT	KGS		
SPEC	1.6(2.0) X W X L	MATERIAL	CORTEN		
PART NO.	CIMC-D02	UNIT	mm	PAGE NO.	5

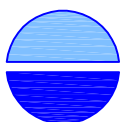

CIMC

1 CORR. 1浪

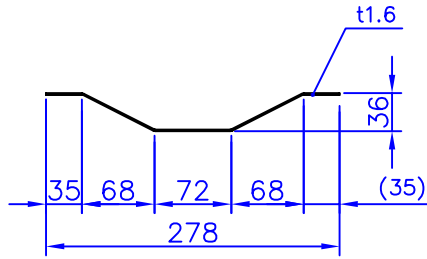

PART NO.	SPEC	WEIGHT
CIMC-D02-02A	1.6X278X150	0.558
CIMC-D02-02B	1.6X278X300	1.116

2 CORR. 2浪

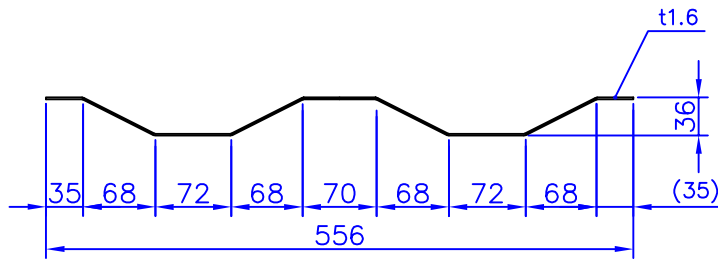

PART NO.	SPEC	WEIGHT
CIMC-D02-02C	1.6X556X150	1.116
CIMC-D02-02D	1.6X556X300	2.233
CIMC-D02-02E	1.6X556X600	4.465

4 CORR. 4浪

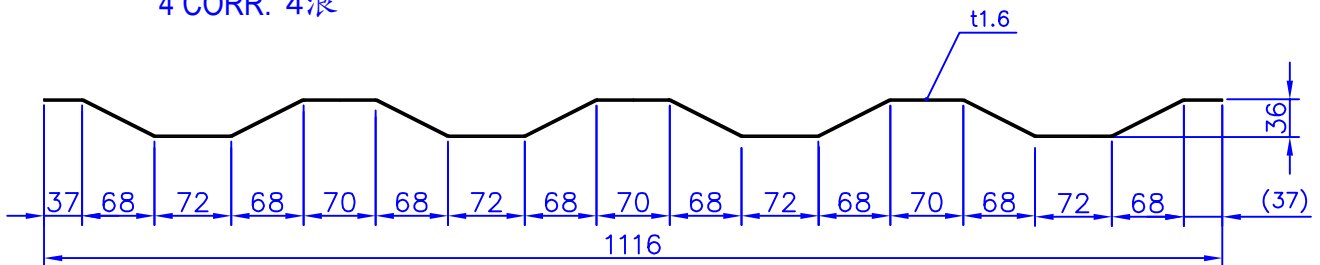

PART NO.	SPEC	WEIGHT
CIMC-D02-02F	1.6X1116X300	4.465
CIMC-D02-02G	1.6X1116X600	8.930
CIMC-D02-02H	1.6X1116X1200	17.860

TITLE	Side Panel Patch 八字侧板补片	WEIGHT	KGS		
SPEC	1.6 X W X L	MATERIAL	CORTEN		
PART NO.	CIMC-D02-02	UNIT	mm	PAGE NO.	6

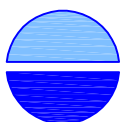

CIMC

四浪前端板

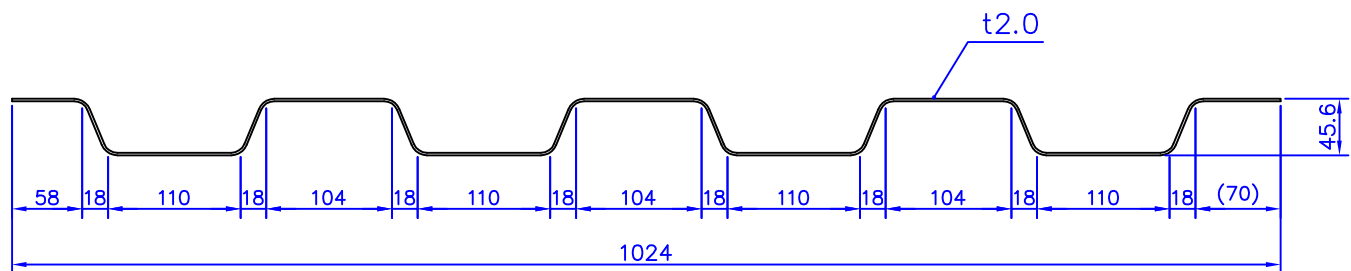

PART NO.	SPEC	WEIGHT
CIMC-D03-01A	2.0X1024X2400	46.158
CIMC-D03-01B	2.0X1024X2700	51.928

长荣前端板

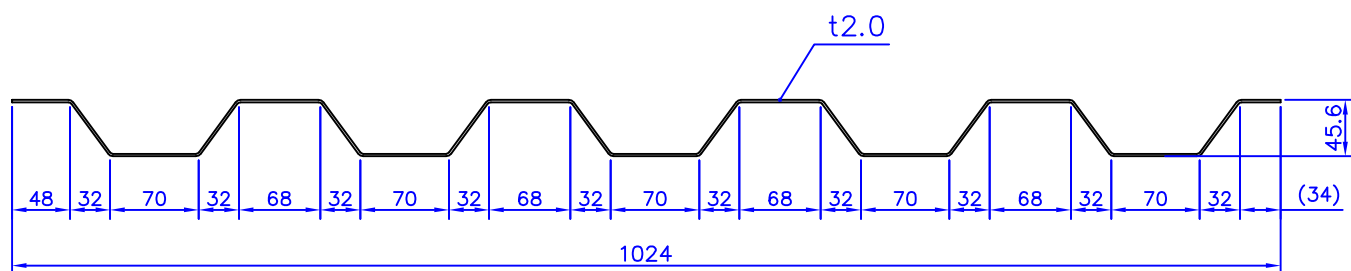

PART NO.	SPEC	WEIGHT
CIMC-D03-02A	2.0X1024X2400	46.158
CIMC-D03-02B	2.0X1024X2700	51.928

TITLE	Front End Panel 前端板	WEIGHT	KGS		
SPEC	2.0 X 1024 X L	MATERIAL	CORTEN		
PART NO.	CIMC-D03-01A/B, 02A/B	UNIT	mm	PAGE NO.	7

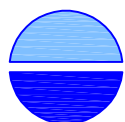

CIMC

1 CORR. 1浪

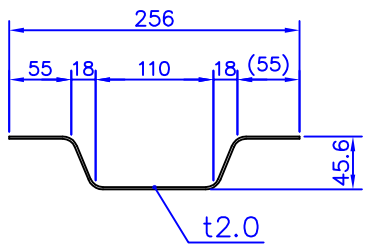

PART NO.	SPEC	WEIGHT
CIMC-D03-03-1	2.0X256X2700	10.921

2 CORR. 2浪

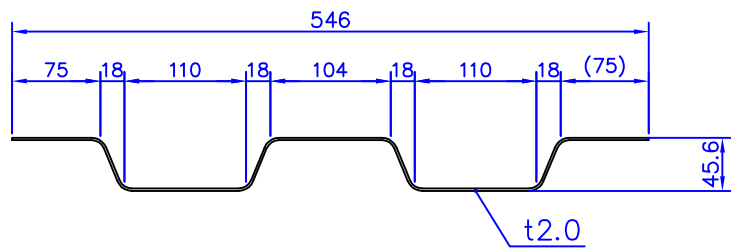

PART NO.	SPEC	WEIGHT
CIMC-D03-04	2.0X546X2700	23.292

3 CORR. 3浪

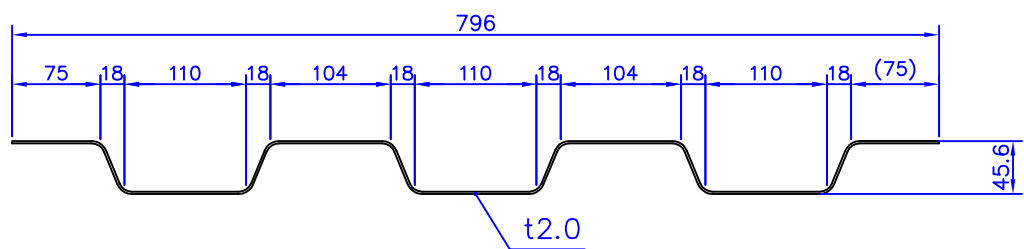

PART NO.	SPEC	WEIGHT
CIMC-D03-05	2.0X796X2700	33.957

TITLE	Front End Panel (Patch) 前端板补片	WEIGHT	KGS		
SPEC	2.0 X W X 2700	MATERIAL	CORTEN		
PART NO.	CIMC-D03-03-1/04/05	UNIT	mm	PAGE NO.	8



CIMC-D04-01A/B
二波门板

CIMC-D04-02A/B
三波门板

CIMC-D04-03A/B
五波门板

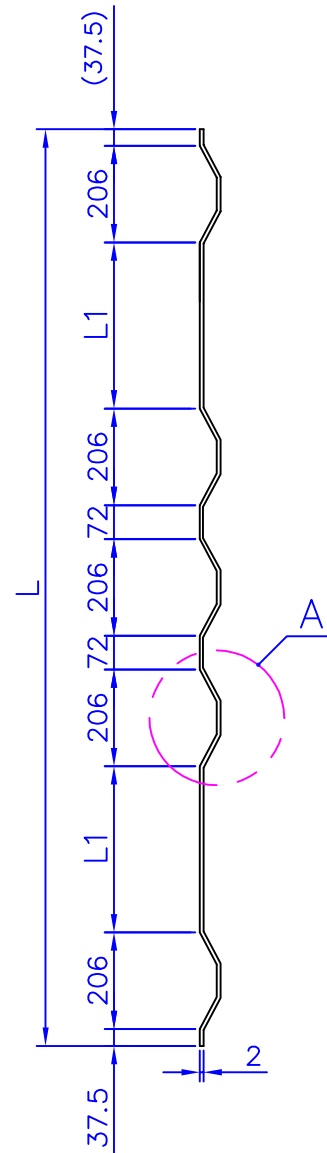
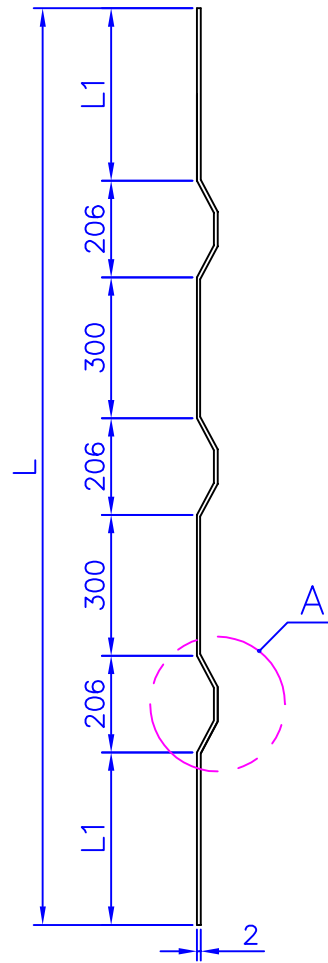
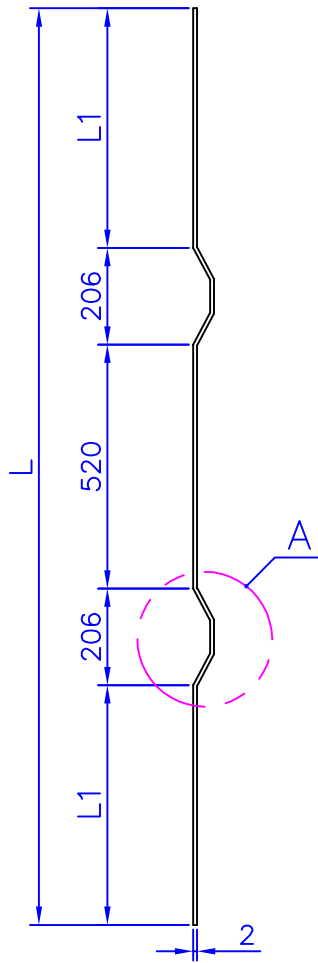

DETAIL A
2:1

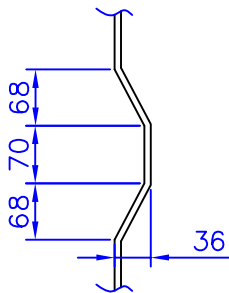

PART NO.	SPEC	L1	WEIGHT
CIMC-D04-01A	2.0X943X1957	512.5	30.516
CIMC-D04-01B	2.0X943X2262	665	36.243
CIMC-D04-02A	2.0X943X1957	369.5	31.023
CIMC-D04-02B	2.0X943X2262	522	36.751
CIMC-D04-03A	2.0X943X1957	354	31.023
CIMC-D04-03B	2.0X943X2262	506	36.751

TITLE	Door Panel 门板	WEIGHT	KGS		
SPEC	2.0 X 943 X L	MATERIAL	CORTEN		
PART NO.	CIMC-D04	UNIT	mm	PAGE NO.	9

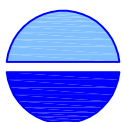

CIMC

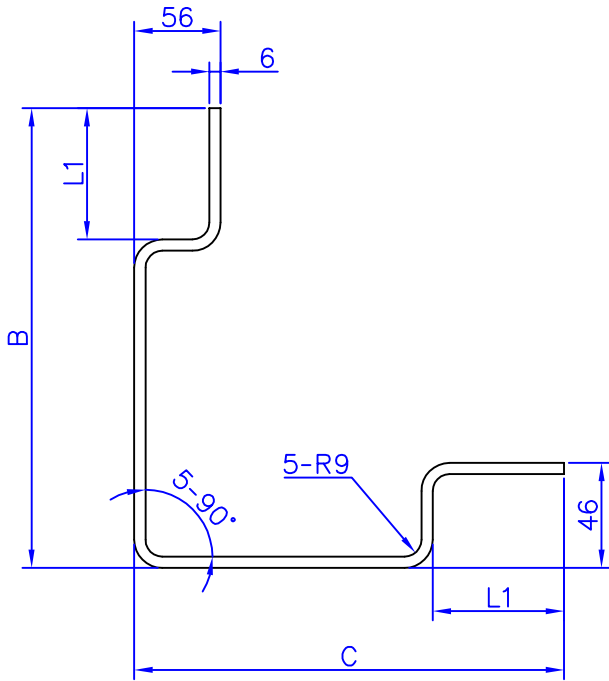

PART NO.	SPEC	B	C	L1	WEIGHT
CIMC-D05-01A	6.0X209X225X2400	209	225	50	54.937
CIMC-D05-01B	6.0X209X225X2700	209	225	50	61.805
CIMC-D05-02A	6.0X229X245X2400	229	245	70	59.459
CIMC-D05-02B-1	6.0X229X245X2700	229	245	70	66.891
CIMC-D05-02B	6.0X229X245X2725	229	245	70	67.941

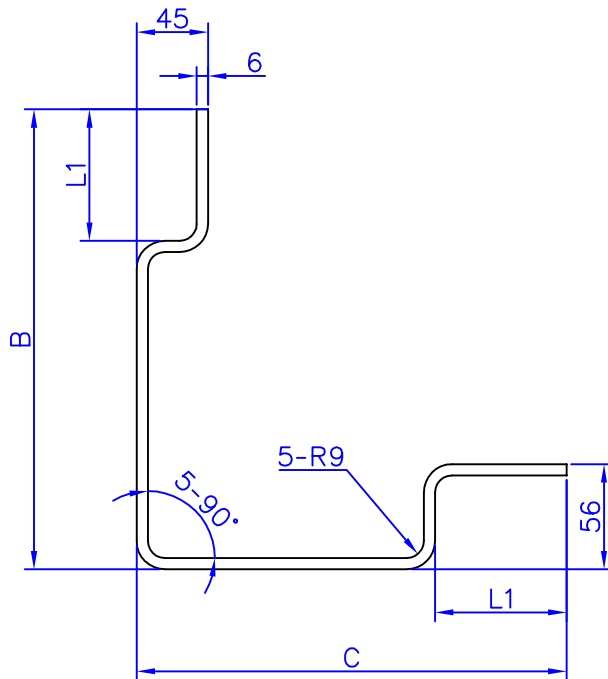

PART NO.	SPEC	B	C	L1	WEIGHT
CIMC-D05-03A	6.0X229X214X2420	229	214	58	56.780
CIMC-D05-03B	6.0X229X214X2743	229	214	58	64.359
CIMC-D05-03C	6.0X229X214X2700	229	214	58	63.350
CIMC-D05-06B	6.0X248X232X2700	248	232	76	67.829
CIMC-D05-07A	6.0X246X231X2420	246	231	75	60.179
CIMC-D05-07B	6.0X246X231X2743	246	231	75	67.701

TITLE	Front Corner Post 前角柱	WEIGHT		KGS	
SPEC	6.0 X B X C X L	MATERIAL		CORTEN	
PART NO.	CIMC-D05	UNIT	mm	PAGE NO.	10

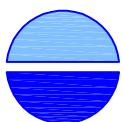

CIMC

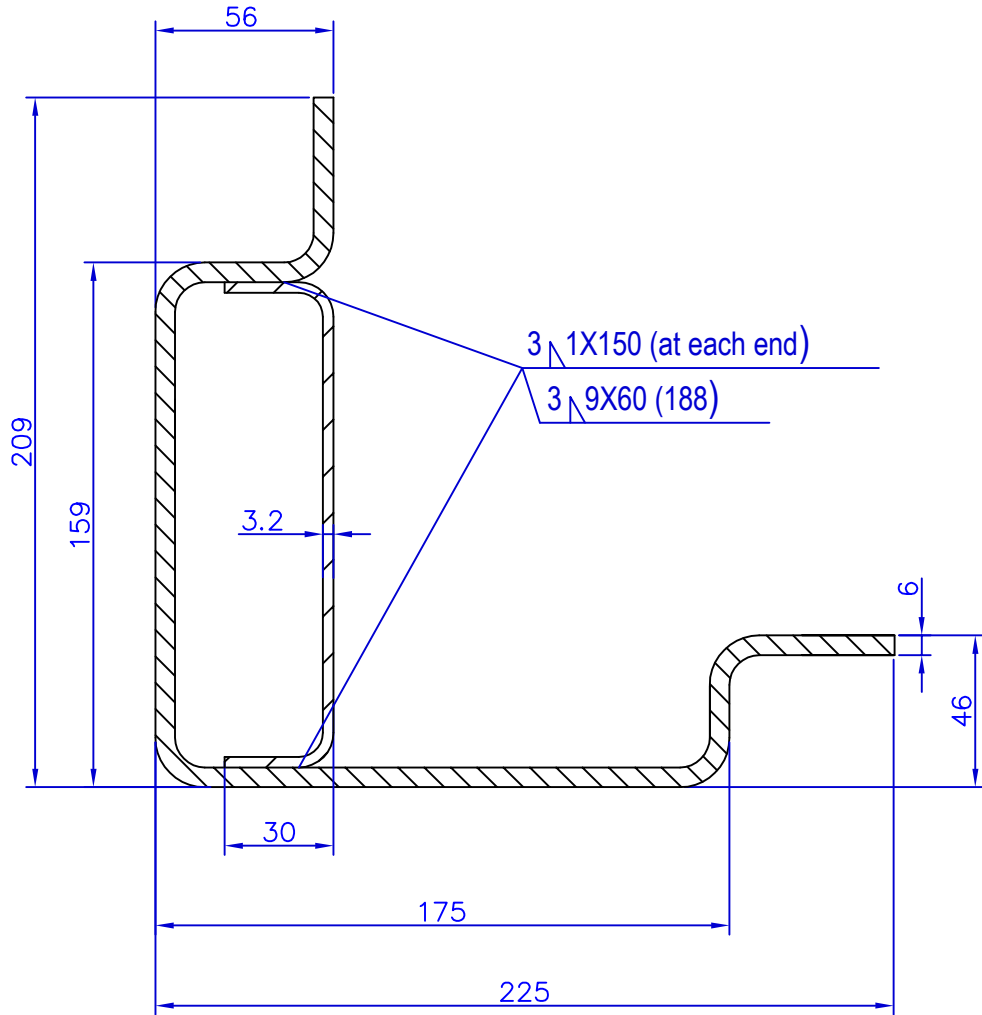

PART NO.	SPEC	WEIGHT
CIMC-D05-05A	6.0X209X225X2420 & 3.2X195X2420	66.915
CIMC-D05-05B	6.0X209X225X2720 & 3.2X195X2720	75.282

TITLE	Front Corner Post with reinforcement inside 加强前角柱	WEIGHT	KGS		
SPEC	L=2420 / 2720	MATERIAL	CORTEN		
PART NO.	CIMC-D05-05A/B	UNIT	mm	PAGE NO.	11

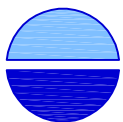

CIMC

Rear Corner Post Outer 后外角柱

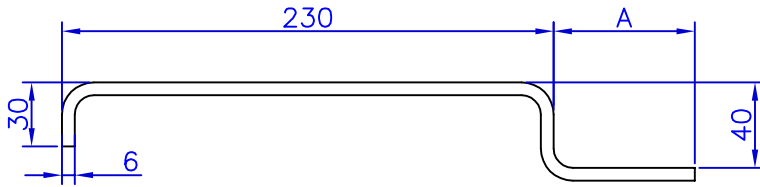

PART NO.	SPEC	A	WEIGHT
CIMC-D06-01A	6.0X50X40X230X2400	50	36.851
CIMC-D06-01B	6.0X50X40X230X2700	50	41.457
CIMC-D06-02A	6.0X70X40X230X2400	70	37.529
CIMC-D06-02B	6.0X70X40X230X2700	70	42.220

Rear Corner Post Inner 后内角柱

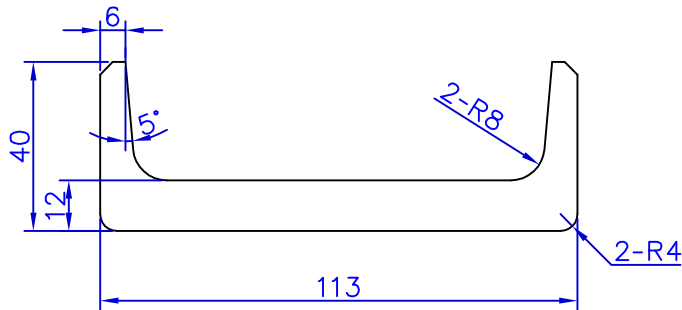

PART NO.	SPEC	MATERIAL	WEIGHT
CIMC-D06-03B	12X113X40X2353	SS50	32.718
CIMC-D06-03C	12X113X40X2657	SS50	36.946

Rear Corner Post with Inner Channel 后外角柱焊槽钢

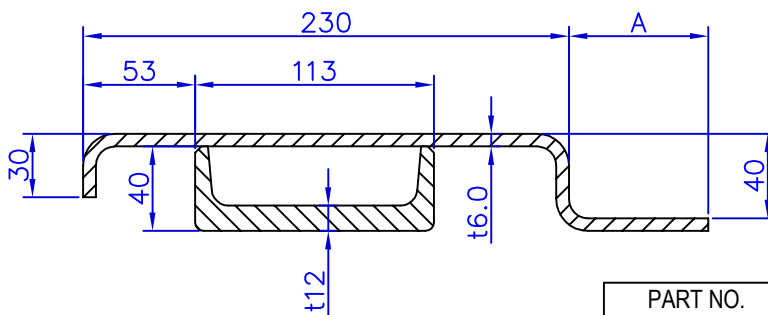

PART NO.	SPEC	A
CIMC-D06-04B	6.0X50X40X230X2400 & 12X113X40X2353	50
CIMC-D06-04C	6.0X50X40X230X2700 & 12X113X40X2657	50
CIMC-D06-05A	6.0X70X40X230X2400 & 12X113X40X2353	70
CIMC-D06-05B	6.0X70X40X230X2700 & 12X113X40X2657	70

TITLE	Rear Corner Post 后外(内)角柱	WEIGHT	KGS		
SPEC		MATERIAL	CORTEN & SS50		
PART NO.	CIMC-D06	UNIT	mm	PAGE NO.	12

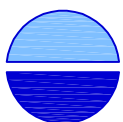

CIMC

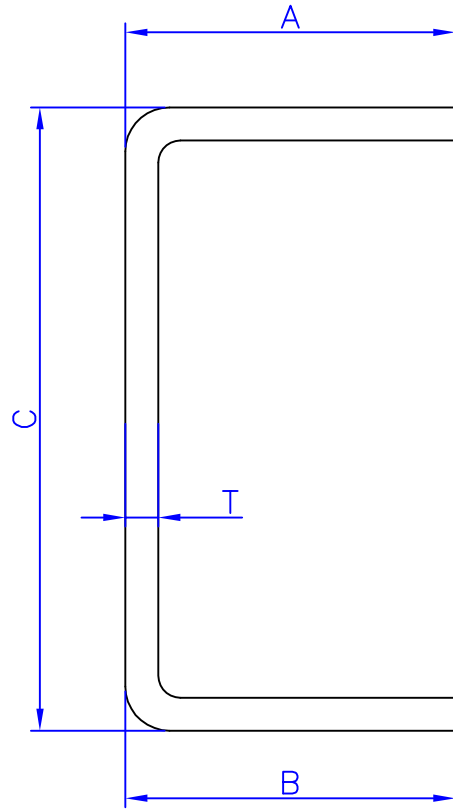

PART NO.	T	A	B	C	SPEC	WEIGHT
CIMC-D07-01A	4.5	45	122	80	4.5X45X122X80X2400	19.415
CIMC-D07-02B	4.5	50	122	80	4.5X50X122X80X2400	19.839
CIMC-D07-02A	4.5	45	85	45	4.5X45X85X45X2400	13.310
CIMC-D07-02B	4.5	45	100	45	4.5X45X100X45X2400	14.582
CIMC-D07-02C	4.5	45	122	45	4.5X45X122X45X2400	16.447
CIMC-D07-02D	4.5	60	120	60	4.5X60X120X60X2420	18.978
CIMC-D07-02E	4.5	60	120	80	4.5X60X120X80X2420	20.688
CIMC-D07-02F	4.5	50	120	50	4.5X50X120X50X2400	17.126
CIMC-D07-03A	4.0	45	122	80	4.0X45X122X80X2400	17.408
CIMC-D07-03B	4.0	45	85	45	4.0X45X85X45X2400	11.832
CIMC-D07-03C	4.0	45	100	45	4.0X45X100X45X2400	13.113
CIMC-D07-03D	4.0	45	122	45	4.0X45X122X45X2400	14.771

TITLE	Cross Member 底横梁	WEIGHT	KGS		
SPEC	TxAxBxCxL	MATERIAL	CORTEN		
PART NO.	CIMC-D07	UNIT	mm	PAGE NO.	13

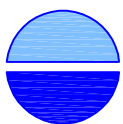

CIMC

CIMC-D08-01C "C" Type

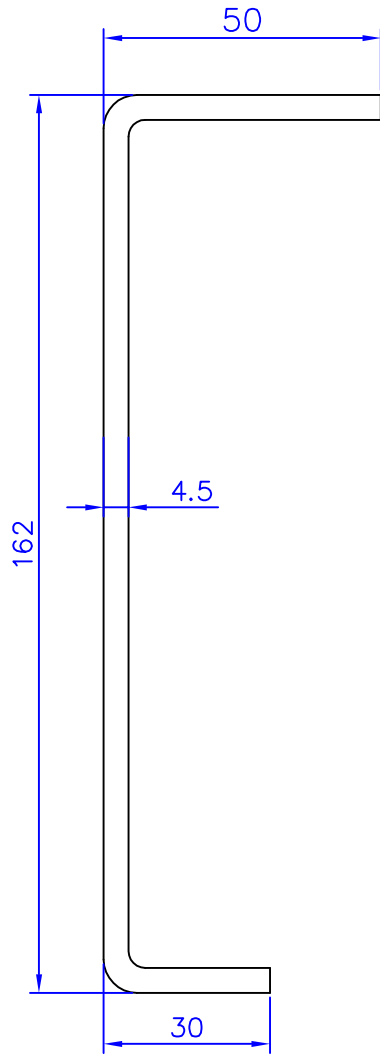

CIMC-D08-02 "Double Z" Type

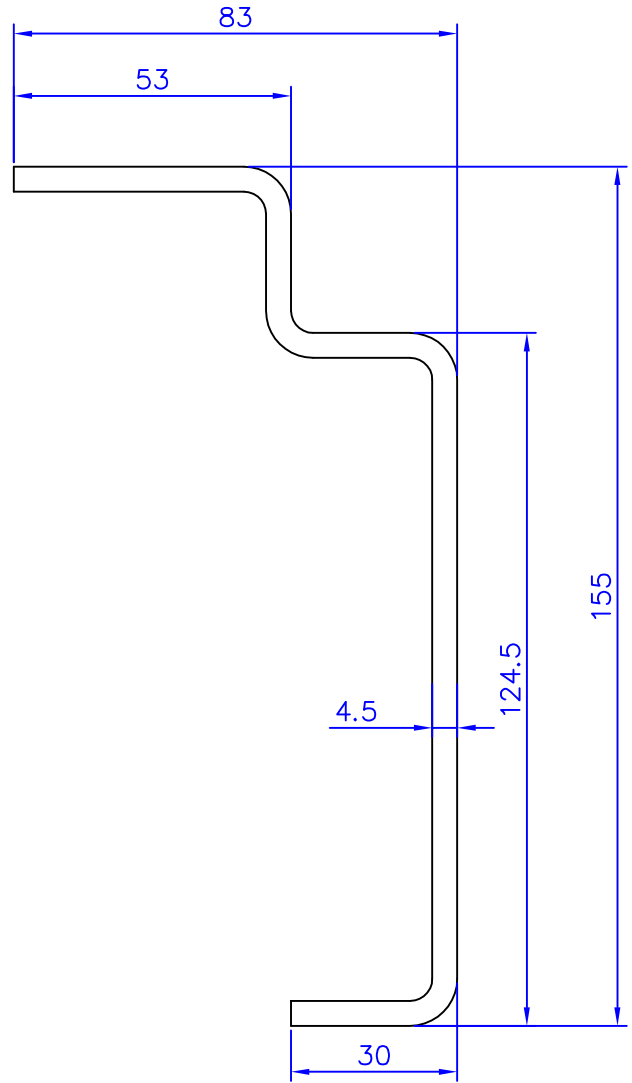

PART NO.	SPEC	WEIGHT
CIMC-D08-01C	4.5X50X162X30X5702	44.716
CIMC-D08-02	4.5X50X155X30X5702	48.342

TITLE	Bottom Side Rail 底侧梁	WEIGHT	KGS		
SPEC	4.5X50X162/155X30X5702	MATERIAL	CORTEN		
PART NO.	CIMC-D08-01C/02	UNIT	mm	PAGE NO.	14

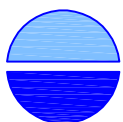

CIMC

CIMC-D09-01A Square Tube 方管

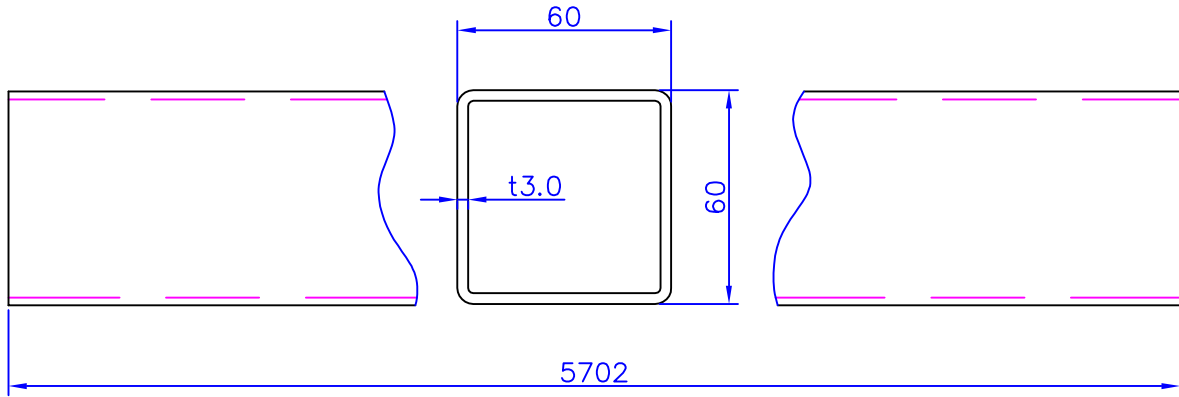

CIMC-D09-02C Flat Steel 扁钢

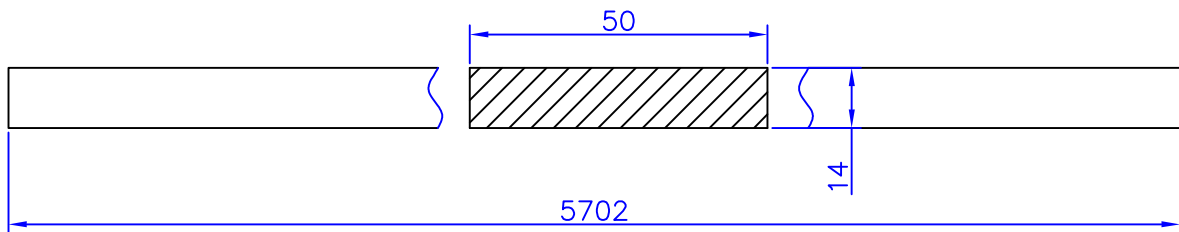

PART NO.	SPEC	MATERIAL	WEIGHT
CIMC-D09-01A	3.0X60X60X5702	CORTEN	32.479
CIMC-D09-02C	14X50X5702	Q235	32.510

TITLE	Top Side Rail 顶纵梁	WEIGHT	KGS		
SPEC		MATERIAL	CORTEN & Q235		
PART NO.	CIMC-D09-01A/02C	UNIT	mm	PAGE NO.	15

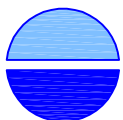

CIMC

CIMC-D09-03 "U" Type

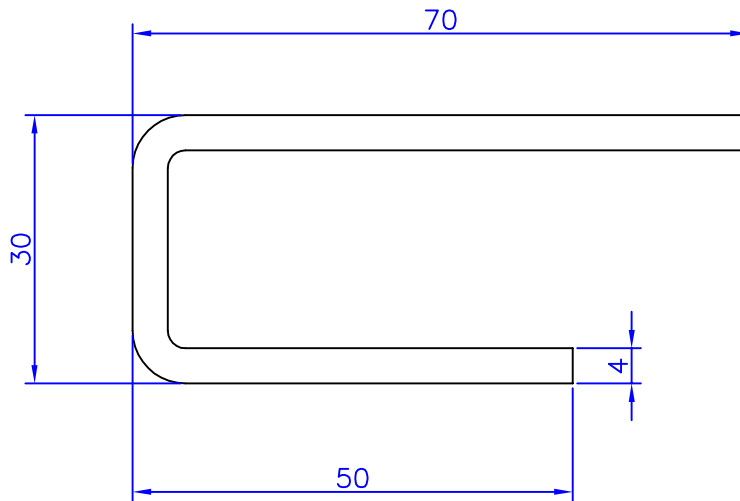

CIMC-D09-04 "W" Type

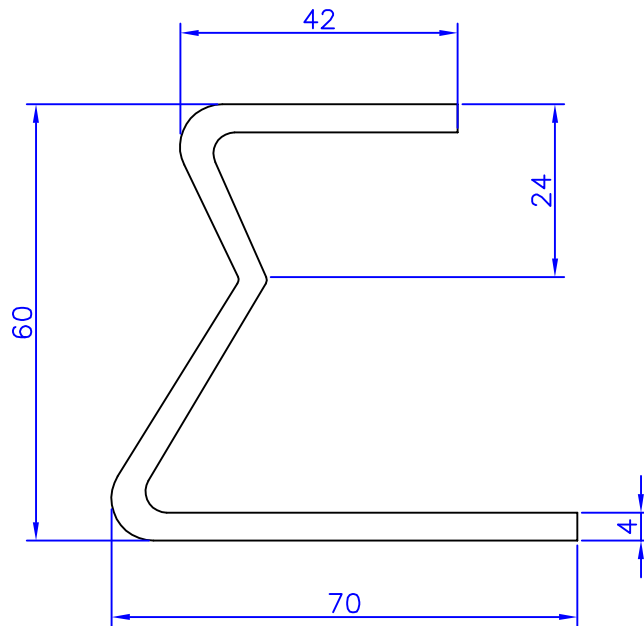

PART NO.	SPEC	WEIGHT
CIMC-D09-03	T=4.0 L=2400 U型	10.174
CIMC-D09-04	T=4.0 L=2400 W型	12.434

TITLE	Top Side Rail 顶纵梁	WEIGHT	KGS		
SPEC	T=4.0 L=2400	MATERIAL	CORTEN		
PART NO.	CIMC-D09-03/04	UNIT	mm	PAGE NO.	16

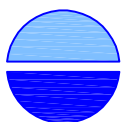

CIMC

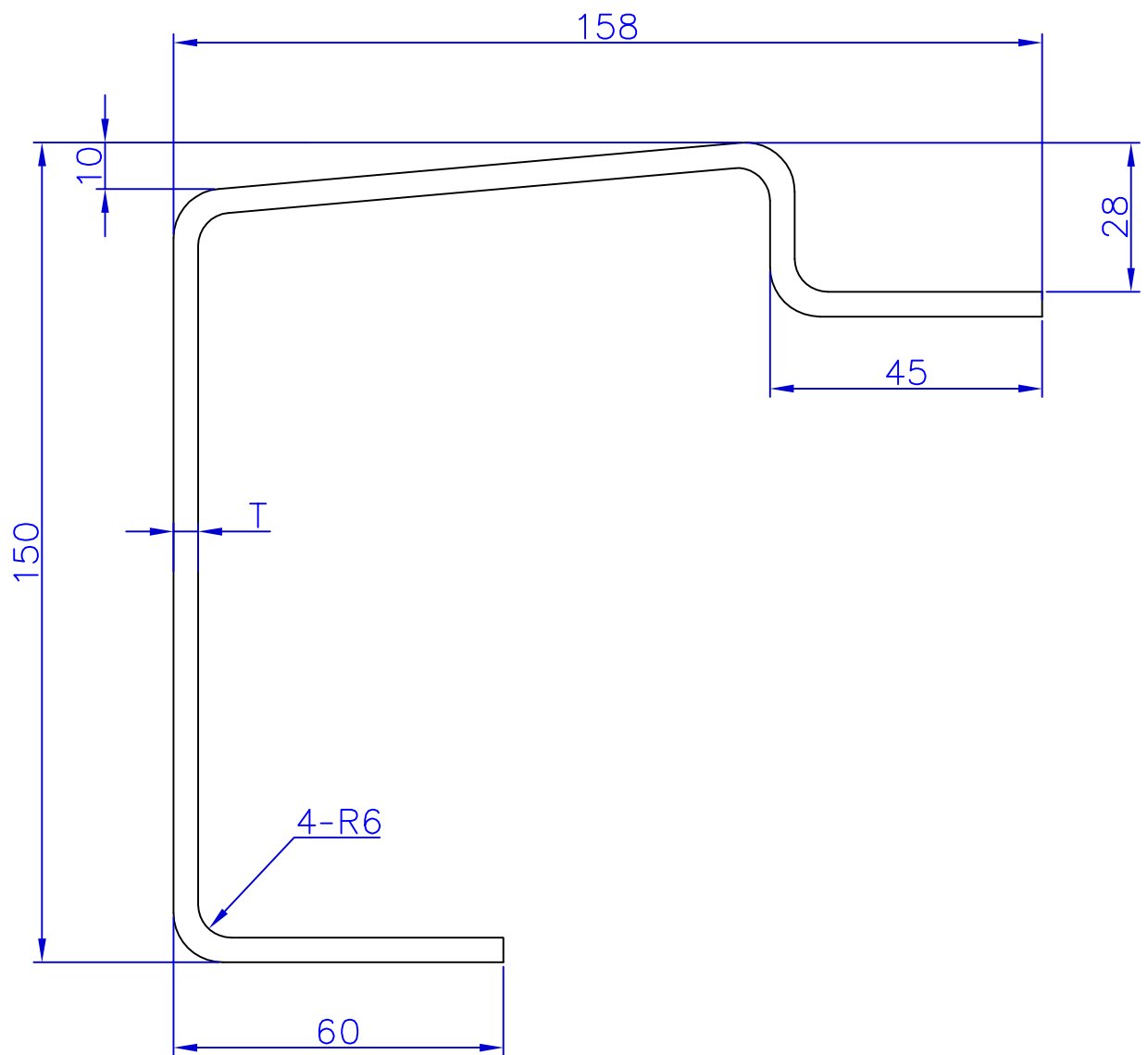

PART NO.	SPEC	WEIGHT
CIMC-D10-01	4.5X158X150X2400	30.690
CIMC-D10-01-4	4.0X158X150X2400	27.280

TITLE	Door Sill 后底梁	WEIGHT	KGS		
SPEC	TX158X150X2400	MATERIAL	CORTEN		
PART NO.	CIMC-D10-01/01-4	UNIT	mm	PAGE NO.	17

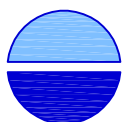

CIMC

CIMC-D10-03 "C" Channel

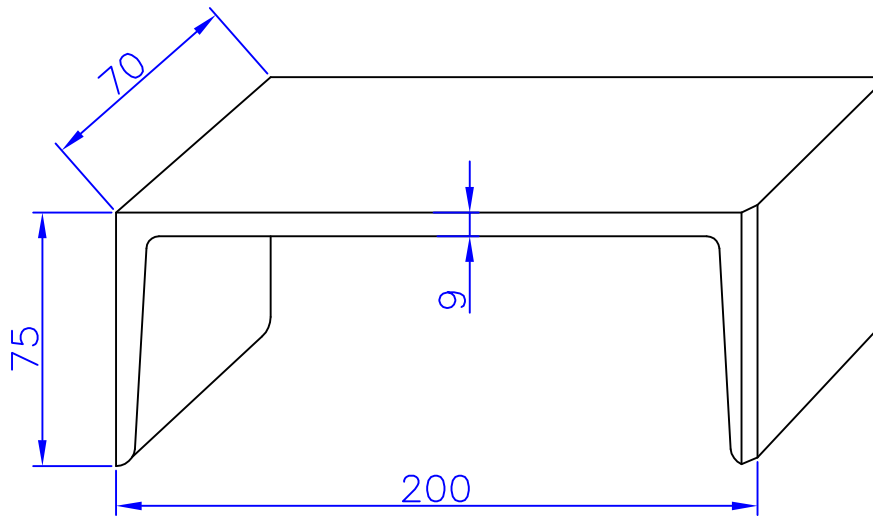

CIMC-D10-04 "V" Channel

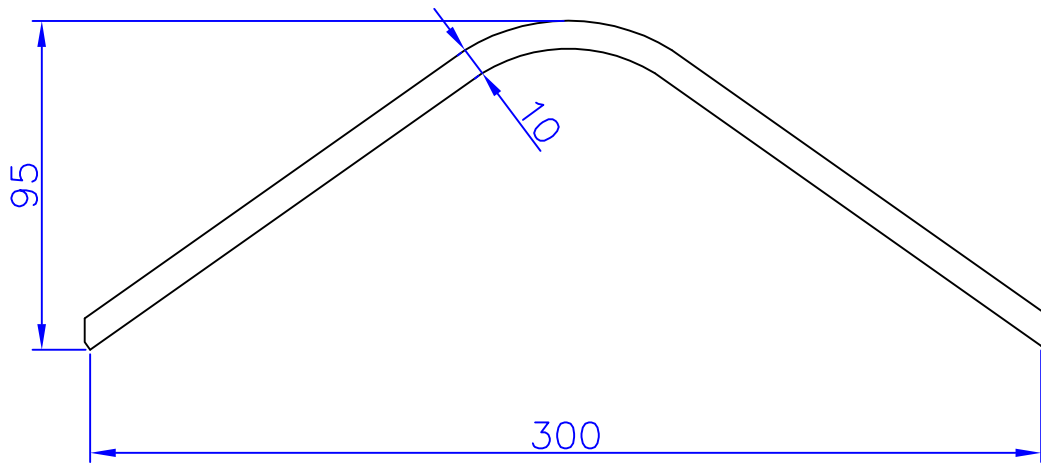

PART NO.	SPEC	WEIGHT
CIMC-D10-03	9.0X200X75X7.5	1.720
CIMC-D10-04	10X300X95X10	2.086

TITLE	"C" Channel / "V" Channel 防撞槽钢	WEIGHT	KGS		
SPEC		MATERIAL	SS400		
PART NO.	CIMC-D10-03/04	UNIT	mm	PAGE NO.	18

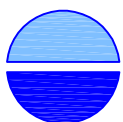

CIMC

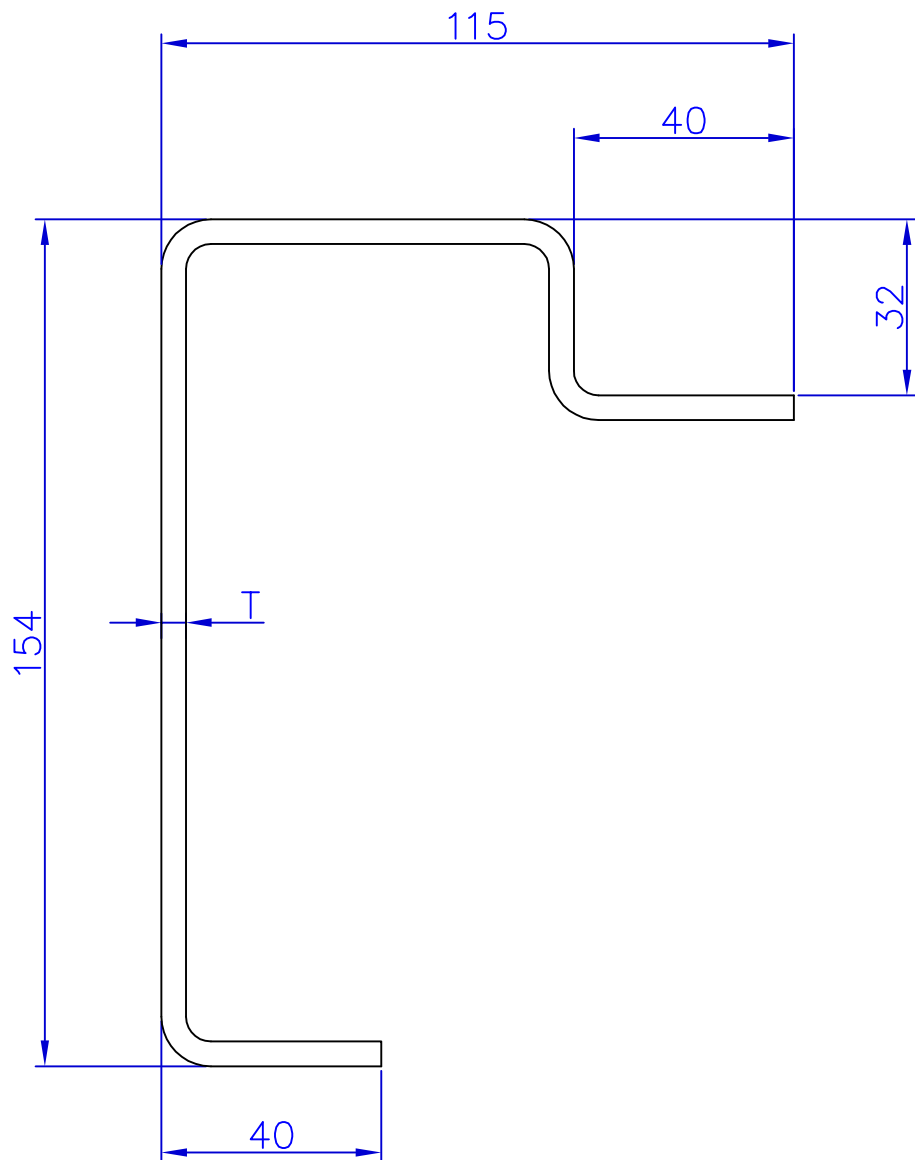

PART NO.	SPEC	WEIGHT
CIMC-D11-01	4.5X115X154X2400	26.621
CIMC-D11-01-11	4.0X115X154X2400	23.889

TITLE	Front Bottom Rail 前底梁	WEIGHT	KGS		
SPEC	TX115X154X2400	MATERIAL	CORTEN		
PART NO.	CIMC-D11-01/01-11	UNIT	mm	PAGE NO.	19

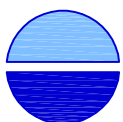

CIMC

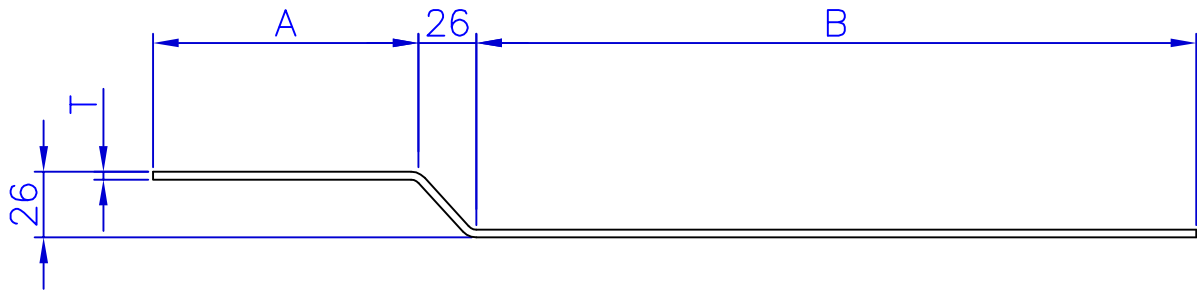

L=2400

PART NO.	SPEC	T	A	B	WEIGHT
CIMC-D12-01	3.0X100X26X277X2400	3.0	100	277	23.117
CIMC-D12-02	3.0X121X26X194X2400	3.0	121	194	19.612

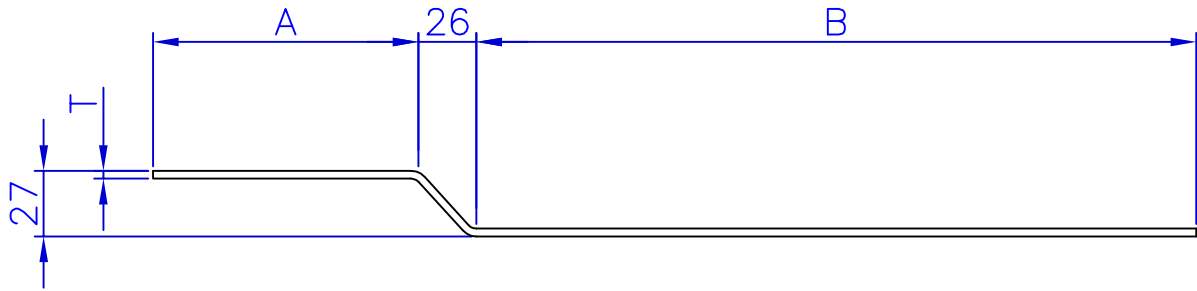

L=2420

PART NO.	SPEC	T	A	B	WEIGHT
CIMC-D12-03	4.0X95X26X304.8X2420	4.0	95	304.8	32.736

TITLE	Top end rail 前顶横梁	WEIGHT	KGS		
SPEC	TXAX26BXL	MATERIAL	CORTEN		
PART NO.	CIMC-D12	UNIT	mm	PAGE NO.	20

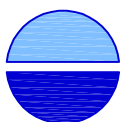

CIMC

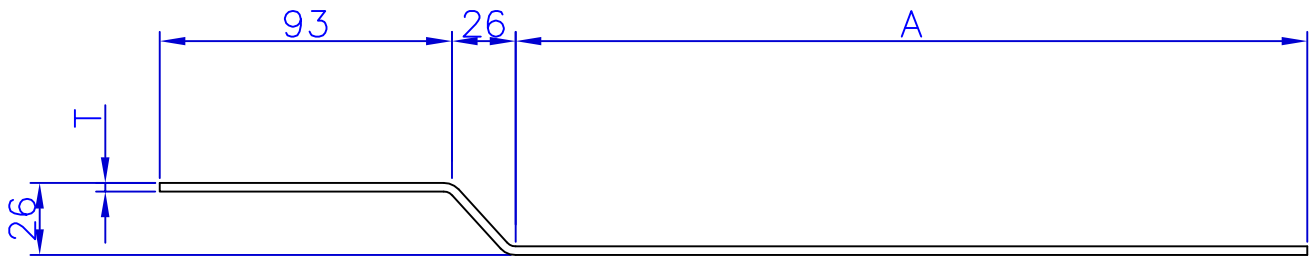

L=2400

PART NO.	SPEC	T	A	WEIGHT
CIMC-D13-01	3.0X93X26X275X2400	3.0	275	22.608
CIMC-D13-02	3.0X93X26X227X2400	3.0	227	19.895

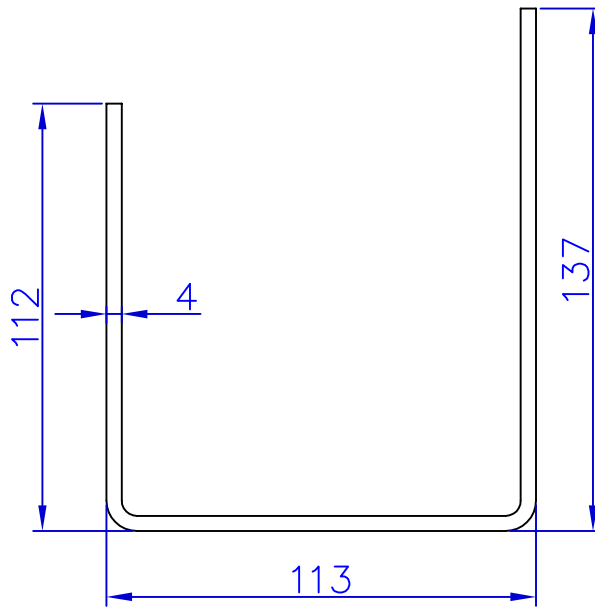

L=2400

PART NO.	SPEC	WEIGHT
CIMC-D12-03	4.0X112X113X137X2400	26.150

TITLE	Door Header Upper/Lower 后顶横梁	WEIGHT	KGS		
SPEC		MATERIAL	CORTEN		
PART NO.	CIMC-D13	UNIT	mm	PAGE NO.	21

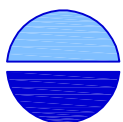

CIMC

CIMC-D14-01 Door Rail 门水平梁 4.0X50X150X50X943

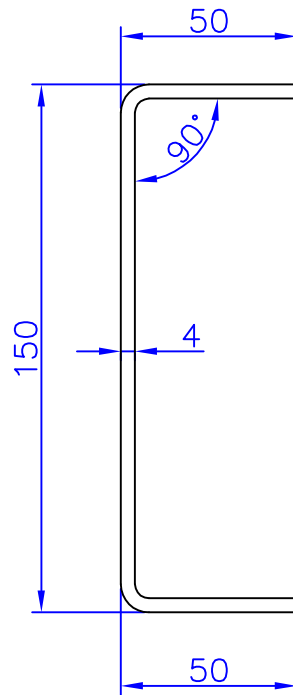

CIMC-D15-01 Floor Space 地板中心梁 2.3X42X28X25X3000

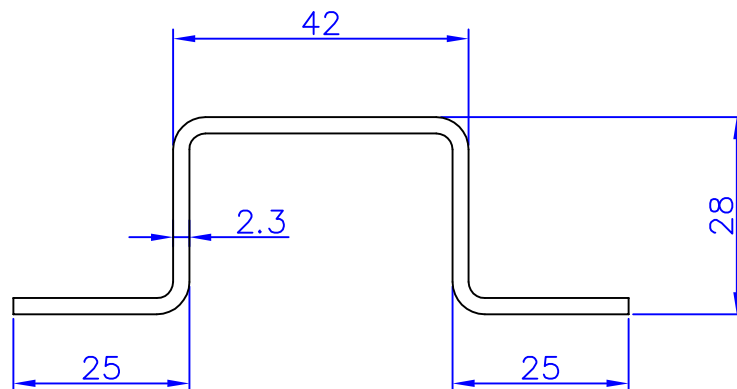

TITLE	Door Rail 门水平梁 / Floor Space 地板中心梁	WEIGHT	6.292 / 7.150 KGS		
SPEC		MATERIAL	CORTEN		
PART NO.	CIMC-D14/15-01	UNIT	mm	PAGE NO.	22

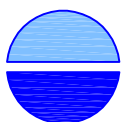

CIMC

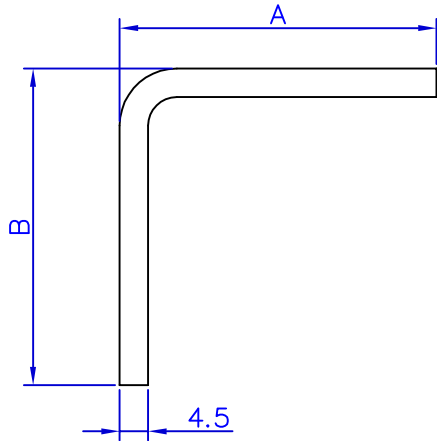

PART NO.	A	B	WEIGHT
CIMC - D16 - 01A	50	30	6.019
CIMC - D16 - 01B	50	50	7.715
CIMC - D16 - 01C	90	60	11.954
CIMC - D16 - 01D	100	30	10.258
CIMC - D16 - 01E	100	40	11.106
CIMC - D16 - 01F	100	45	11.530
CIMC - D16 - 01G	100	50	11.954
CIMC - D16 - 01H	100	80	14.497
CIMC - D16 - 01I	110	45	12.378
CIMC - D16 - 01J	110	50	12.802
CIMC - D16 - 01K	115	45	12.802
CIMC - D16 - 01L	115	50	13.226
CIMC - D16 - 01M	120	30	11.954
CIMC - D16 - 01N	120	40	12.802
CIMC - D16 - 01O	120	45	13.226
CIMC - D16 - 01P	120	50	13.650
CIMC - D16 - 01Q	120	60	14.497
CIMC - D16 - 01R	120	80	16.193
CIMC - D16 - 01S	140	40	14.497
CIMC - D16 - 01T	150	60	17.719

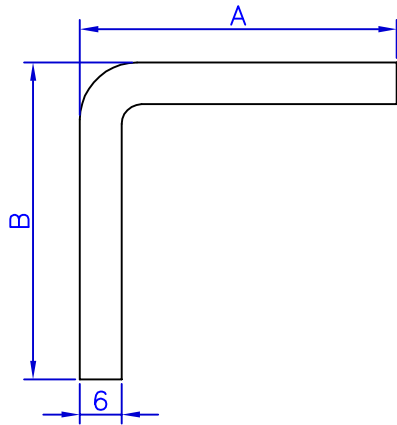

PART NO.	A	B	WEIGHT
CIMC - D16 - 02A	130	120	26.904
CIMC - D16 - 02B	100	100	21.252
CIMC - D16 - 02C	135	150	30.860
CIMC - D16 - 02D	50	30	1.922
CIMC - D16 - 02E	60	30	8.817
CIMC - D16 - 02F	55	35	8.817

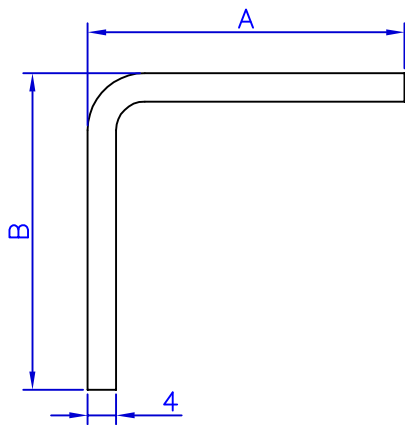

PART NO.	A	B	WEIGHT
CIMC - D16 - 03A	50	30	5.426
CIMC - D16 - 03B	50	50	6.933
CIMC - D16 - 03C	90	60	10.701
CIMC - D16 - 03D	100	30	9.194
CIMC - D16 - 03E	110	45	11.078
CIMC - D16 - 03F	110	80	13.716
CIMC - D16 - 03G	115	45	11.455
CIMC - D16 - 03H	120	30	10.701
CIMC - D16 - 03I	140	40	12.962
CIMC - D16 - 03J	150	60	15.223

TITLE	Angle 角铁	WEIGHT	KGS		
SPEC	L=2400	MATERIAL	CORTEN		
PART NO.	CIMC-D16-0X	UNIT	mm	PAGE NO.	23

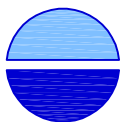

CIMC

Top / Bottom End Rail (Square Tube) 前顶/底梁

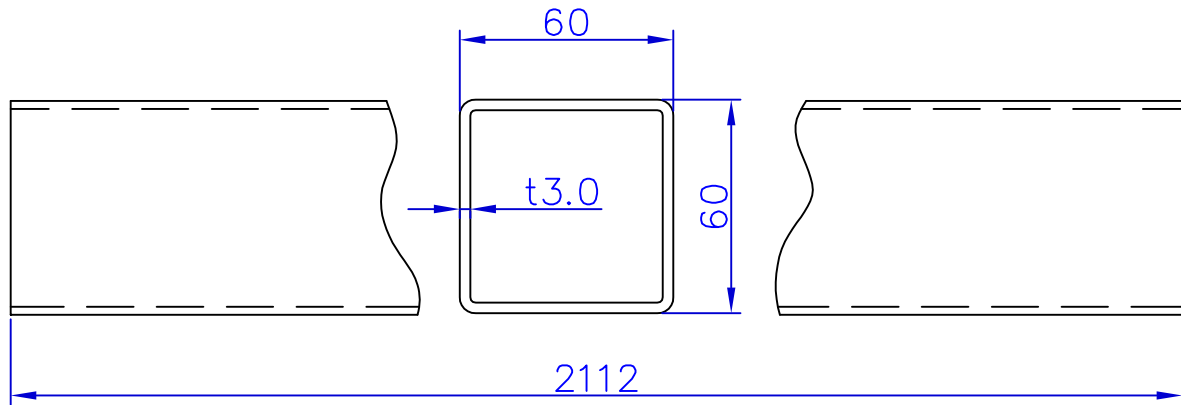

PART NO.	SPEC	WEIGHT
CIMC-D17-01A	3.0X60X60X2112	12.070

Door Edge Member 门立柱

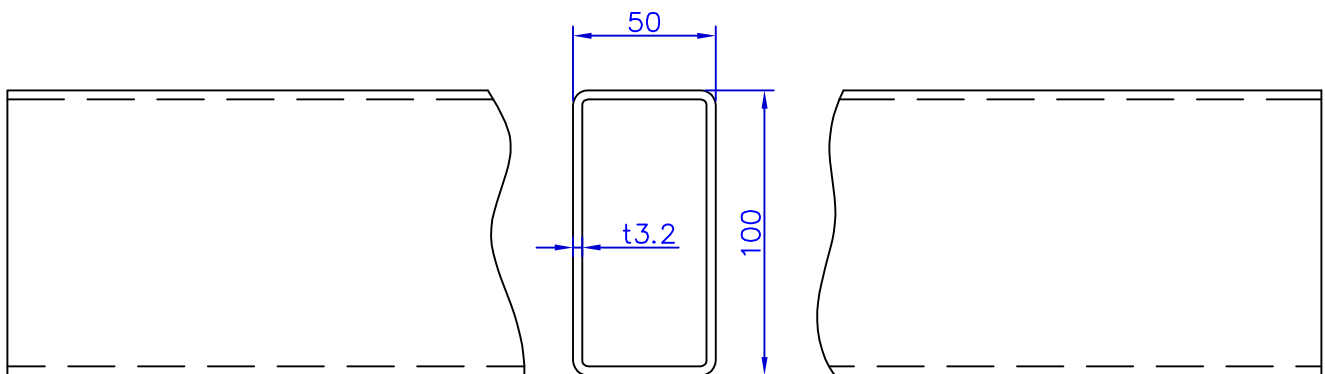

PART NO.	SPEC	WEIGHT
CIMC-D18-01A	3.2X50X100X2248	17.090
CIMC-D18-01B	3.2X50X100X2552	19.410

TITLE	Square Tube 前顶(底)梁/Door Edge Member 门立柱	WEIGHT	KGS		
SPEC		MATERIAL	CORTEN		
PART NO.	CIMC-D17/18	UNIT	mm	PAGE NO.	24

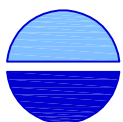

CIMC

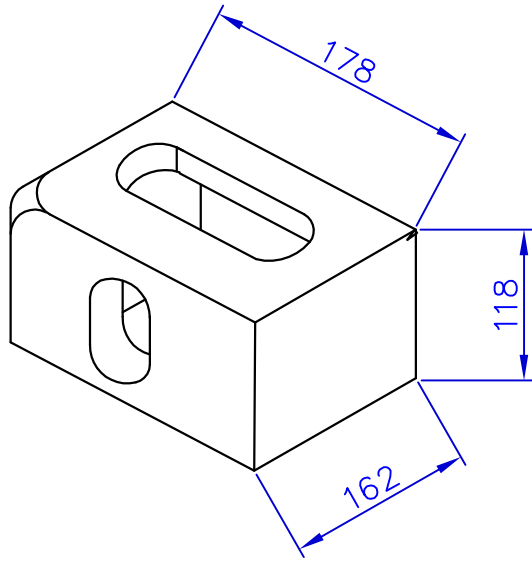

A

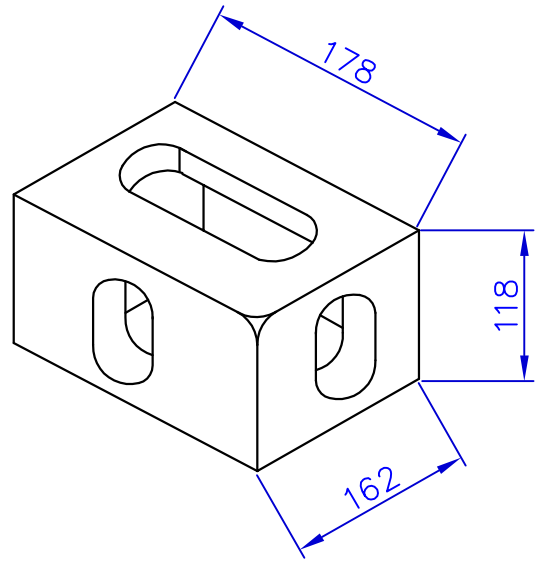

C

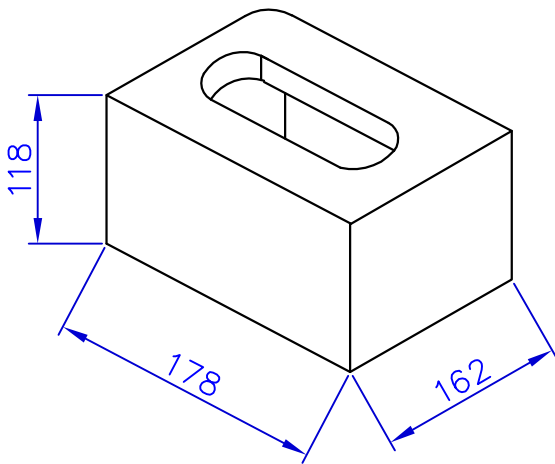

B

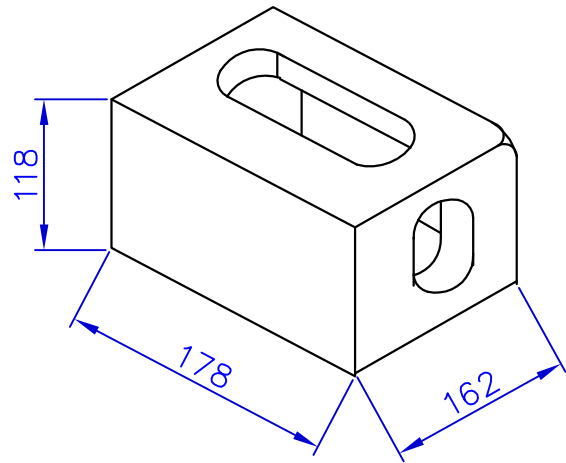

D

ITEM	DESCRIPTION
A	CIMC-D19-01-1 BL, FOR FRONT LOWER RH OR REAR LOWER LH POSTION
B	CIMC-D19-01-2 BR, FOR FRONT LOWER LH OR REAR LOWER RH POSTION
C	CIMC-D19-01-3 TL, FOR FRONT TOP RH OR REAR TOP LH POSTION
D	CIMC-D19-01-4 TR, FOR FRONT TOP LH OR REAR TOP RH POSTION

TITLE	Corner Casting 角件	WEIGHT	88.00 KGS		
SPEC	178X162X118	MATERIAL	SCW490		
PART NO.	CIMC-D19-01	UNIT	mm	PAGE NO.	25

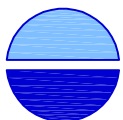

CIMC

CIMC-D20-01A

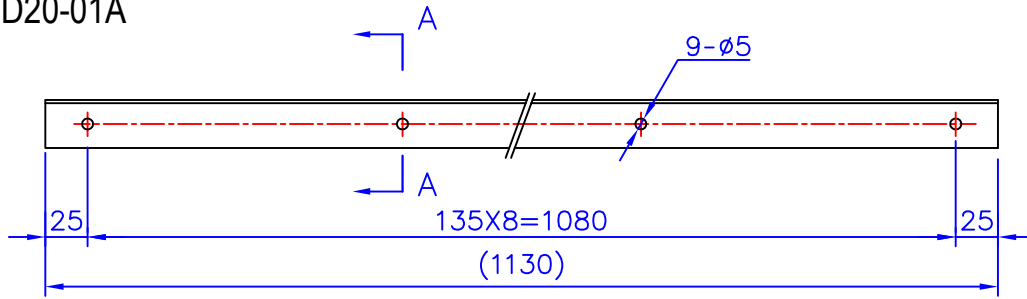

CIMC-D20-01B

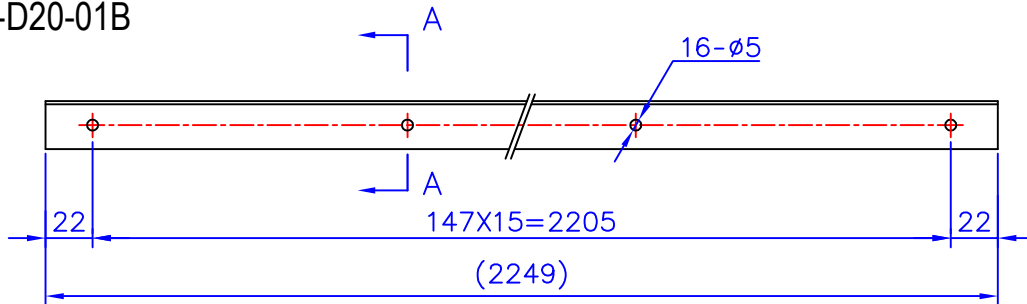

CIMC-D20-01C

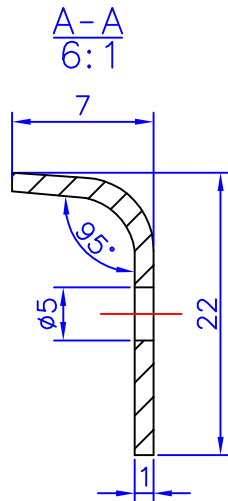
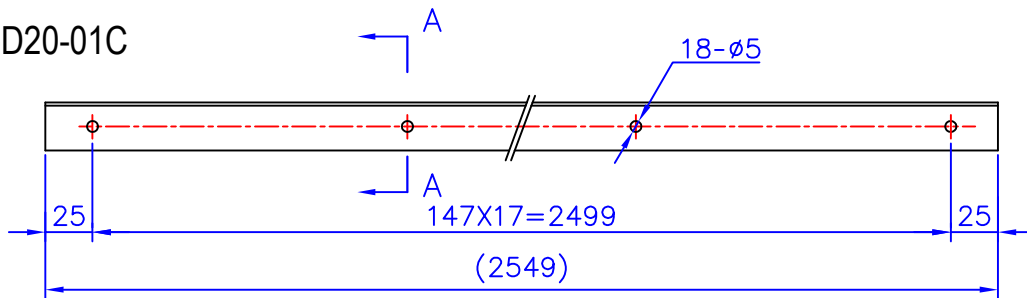

1套/1SET		
水平	Horizongtal	4 PCS
竖直	Vertical	3 PCS

TITLE	Stainless Door Seal Retainer Strip 门压条	WEIGHT	0.150/0.305/0.305 KGS		
SPEC	1.0X22X7XL	MATERIAL	SUS304		
PART NO.	CIMC-D20-01A/B/C	UNIT	mm	PAGE NO.	26

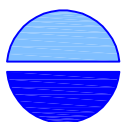

CIMC

CIMC-D20-03A

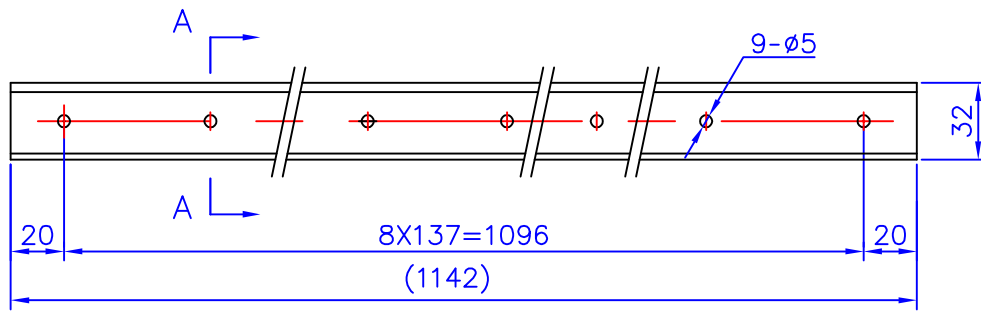

CIMC-D20-03B

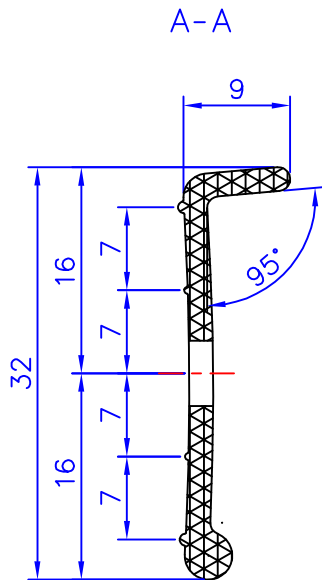
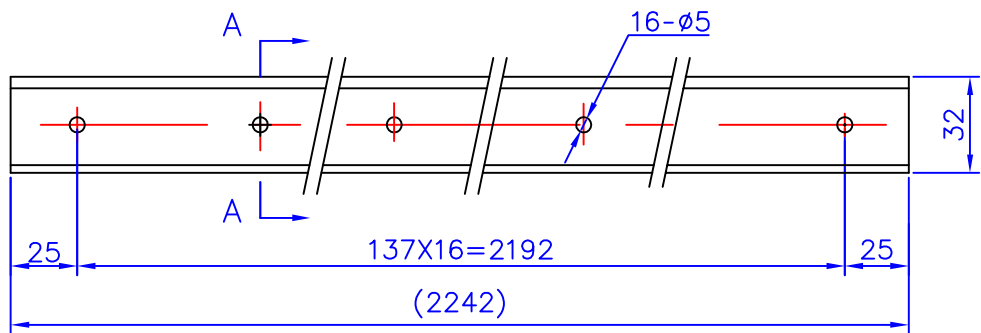

1套/1SET		
水平	Horizongtal	4 PCS
竖直	Vertical	3 PCS

TITLE	Stainless Door Seal Retainer Strip 门压条	WEIGHT	KGS		
SPEC	2.0X32X9XL	MATERIAL	ABS		
PART NO.	CIMC-D20-03A/B	UNIT	mm	PAGE NO.	27

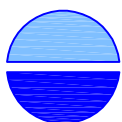

CIMC

Cam (LH/RH) 锁头 (左/右)

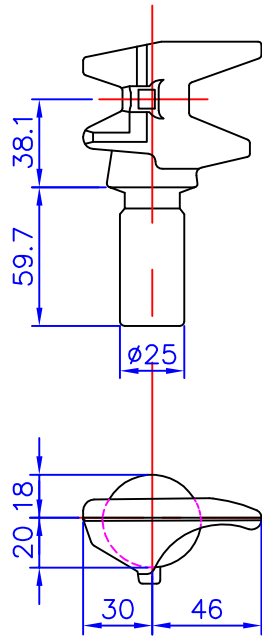

CIMC-D23-01B
RH (右)

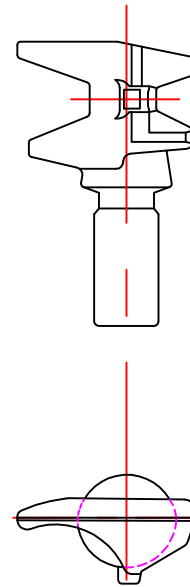

CIMC-D23-01A
LH (左)

Security Cam (LH/RH) 安全锁头 (左/右)
仅世珍供货

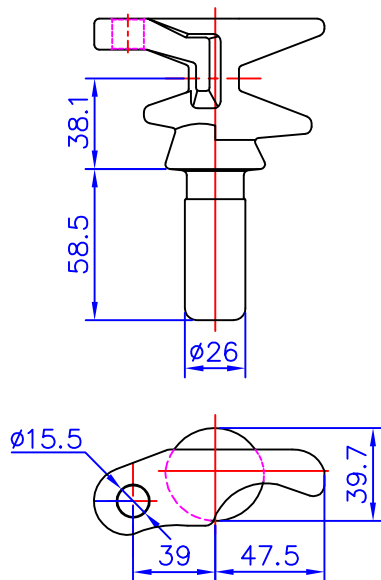

CIMC-D23-01C
RH (右)

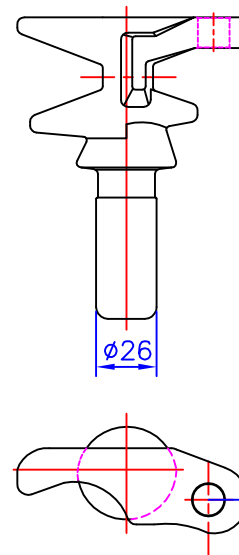

CIMC-D23-01D
LH (左)

TITLE	Cam 锁头	WEIGHT	0.610/0.610/0.750/0.750 KGS		
SPEC		MATERIAL	SS400/Q235B		
PART NO.	CIMC-D23-01A/B/C/D	UNIT	mm	PAGE NO.	29

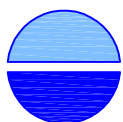

CIMC

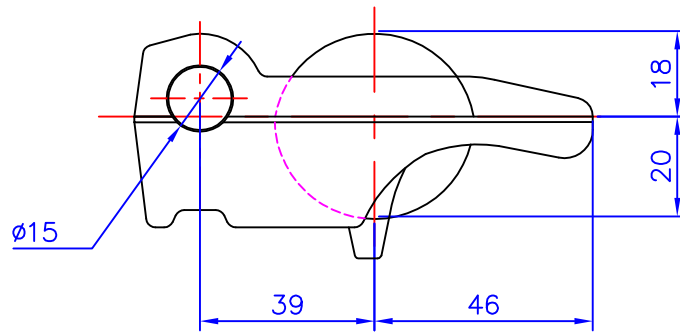
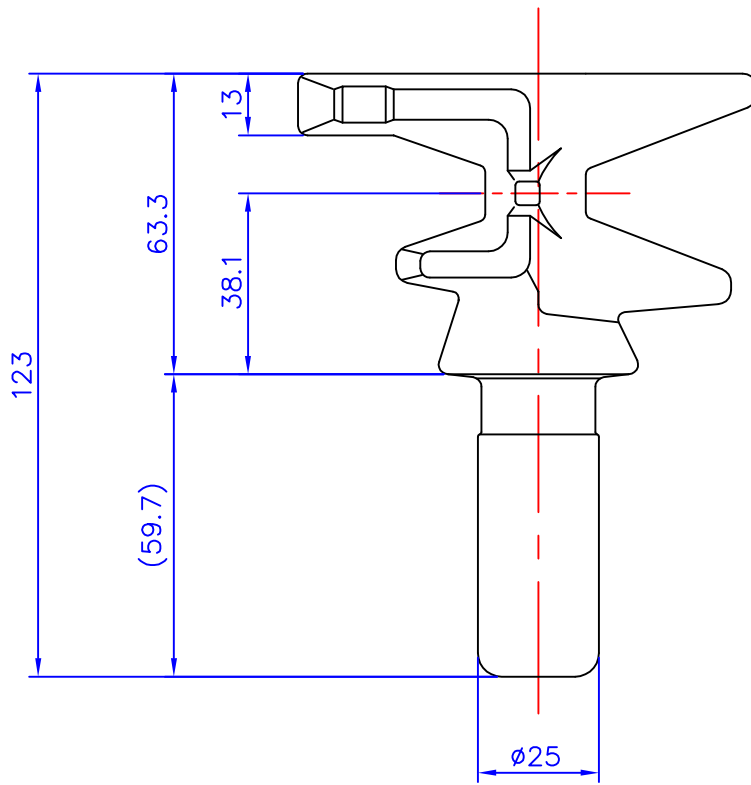

TITLE	Security Cam R.H 有孔锁头 (右)	WEIGHT	0.900 KGS		
SPEC	MAERSK 马士基型	MATERIAL	SS400/Q235B		
PART NO.	CIMC-D23-01G	UNIT	mm	PAGE NO.	30

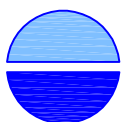

CIMC

Keeper (LH/RH) 锁座 (左/右)
For Corrugated Door

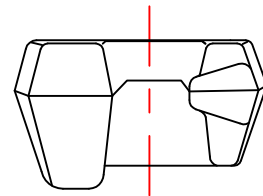
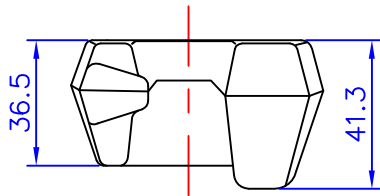
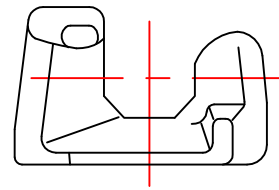
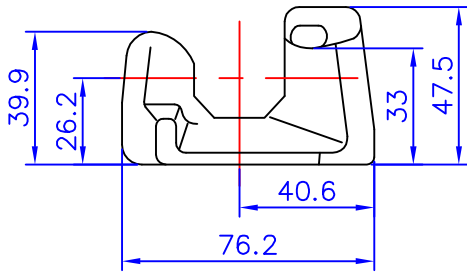

CIMC-D23-02A
LH (左)

CIMC-D23-02B
RH (右)

Keeper (LH/RH) 平门锁座 (左/右)
For Flat Door

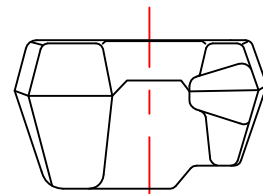
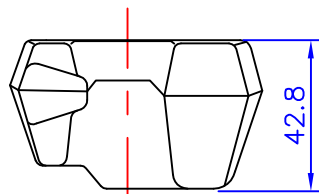
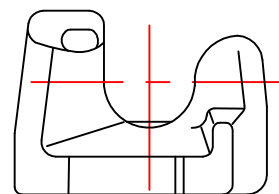
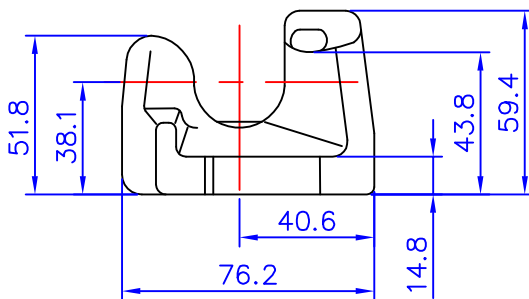

CIMC-D23-02C
LH (左)

CIMC-D23-02D
RH (右)

TITLE	Keeper 锁座	WEIGHT	0.400/0.400/0.600/0.600 KGS		
SPEC		MATERIAL	SS400/Q235B		
PART NO.	CIMC-D23-02A/B/C/D	UNIT	mm	PAGE NO.	31

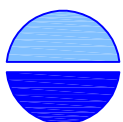

CIMC

CIMC-D23-02E
RH(右)

CIMC-D23-02F
LH(左)

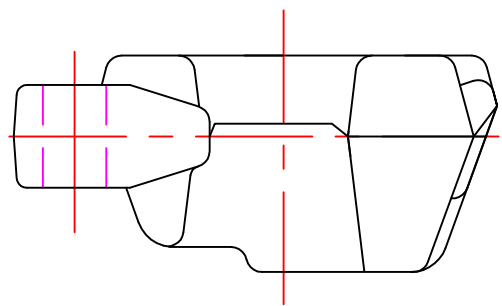
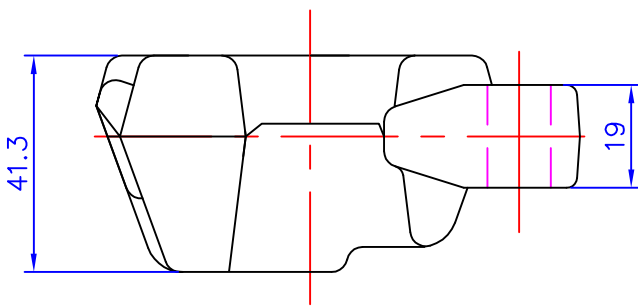
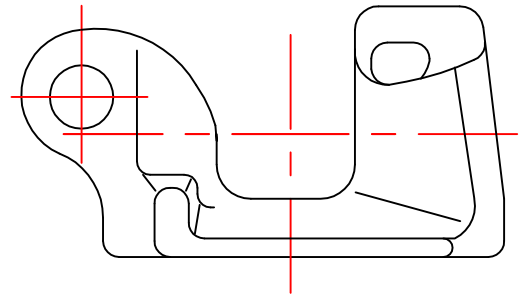
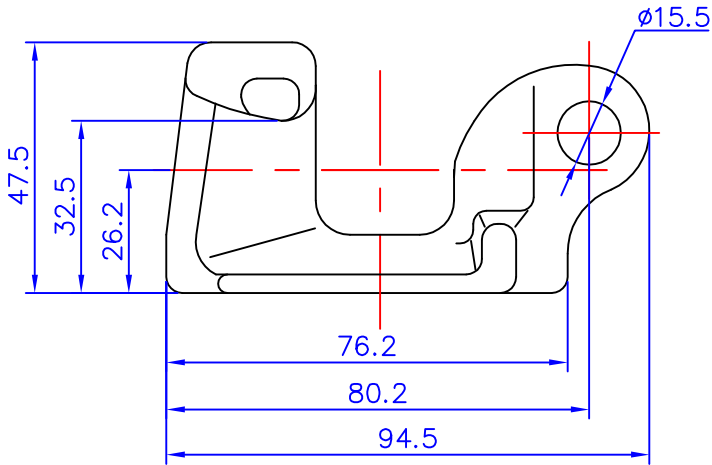

仅世珍供货

TITLE	Security Keeper (LH / RH) 安全锁座(左/右)	WEIGHT	0.450 KGS		
SPEC		MATERIAL	SS400/Q235B		
PART NO.	CIMC-D23-02E/F	UNIT	mm	PAGE NO.	32

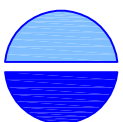

CIMC

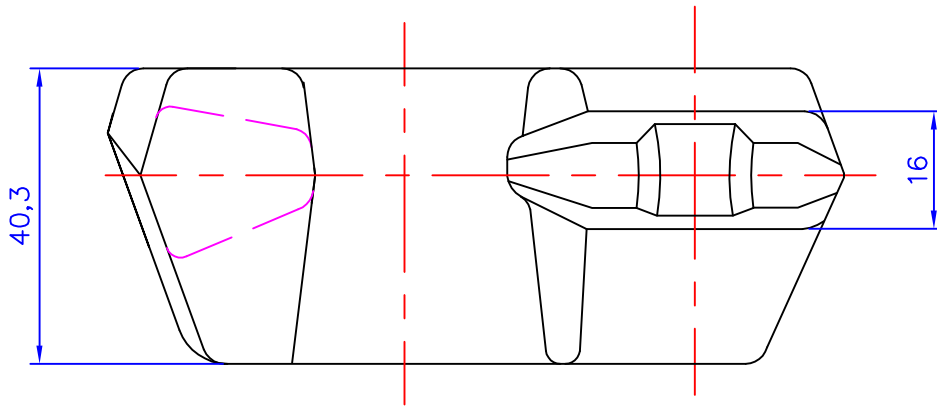
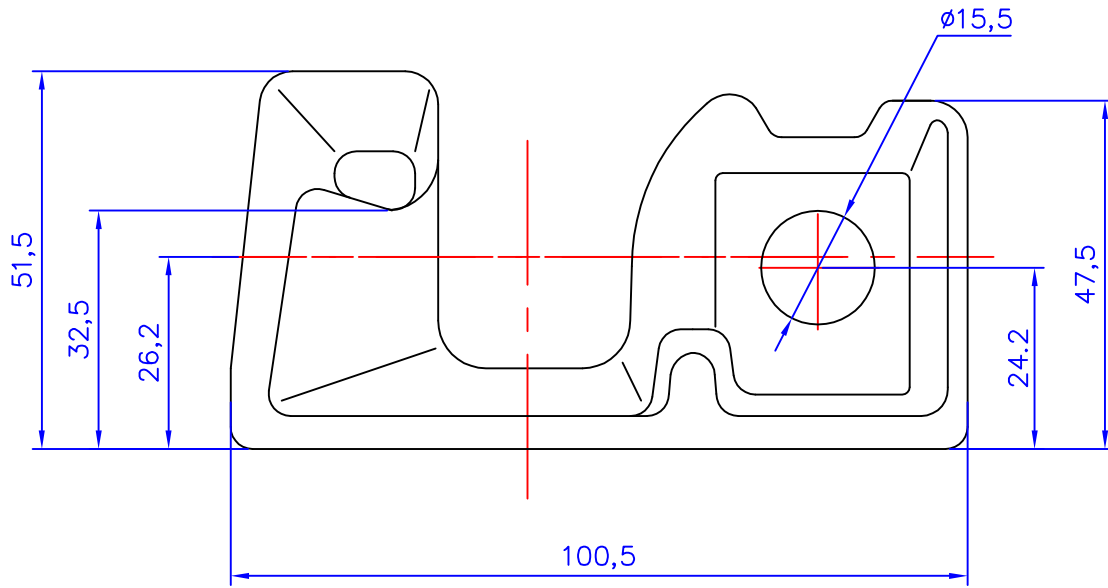

TITLE	Security Keeper (RH) 有孔锁座(右)	WEIGHT	0.600 KGS		
SPEC	Maersk Type 马士基型	MATERIAL	SS400/Q235B		
PART NO.	CIMC-D23-02G	UNIT	mm	PAGE NO.	33

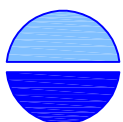

CIMC

Bearing Bracket Outer L 大托架 (外)
CIMC-D23-03

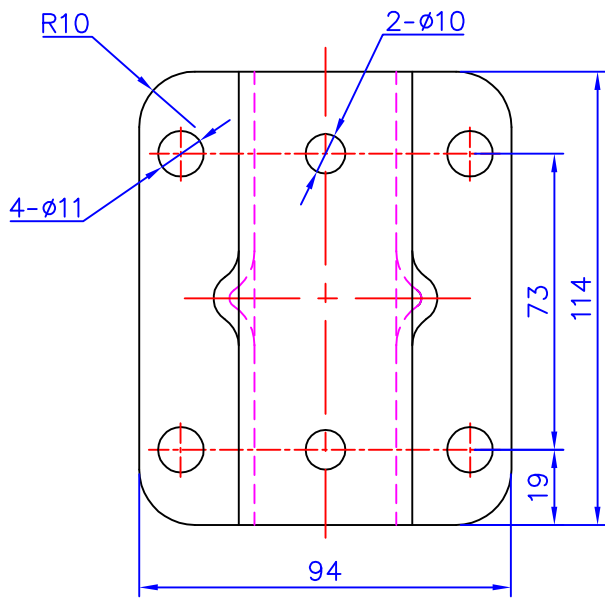
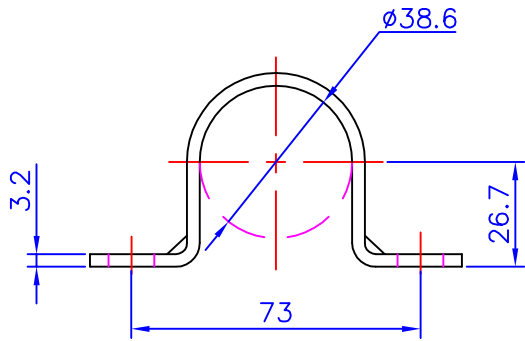

Bearing Bracket Inner L 大托架 (内)
CIMC-D23-04

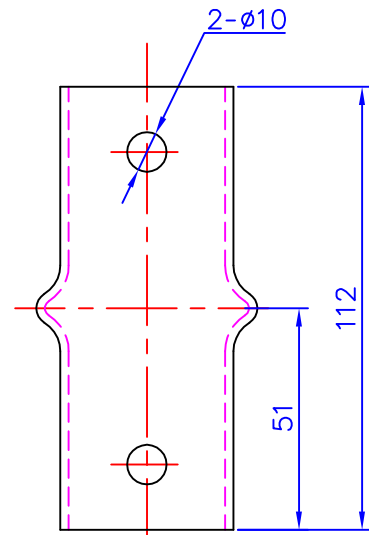
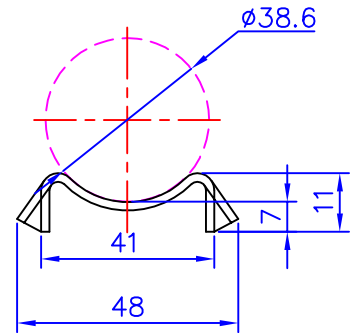

TITLE	Bearing Bracket L 大托架外/内	WEIGHT	0.430/0.090 KGS		
SPEC		MATERIAL	SS400/Q235B		
PART NO.	CIMC-D23-03/04	UNIT	mm	PAGE NO.	34

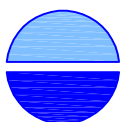

CIMC

Bearing Bracket Outer S 小托架 (外)
CIMC-D23-05

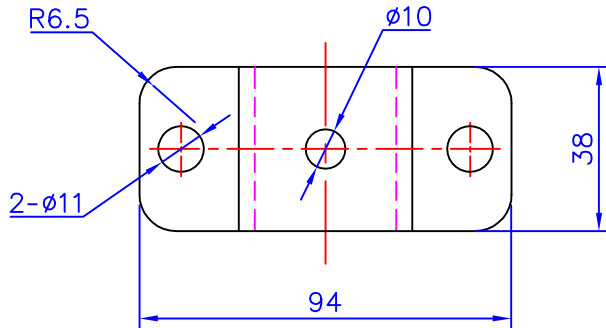
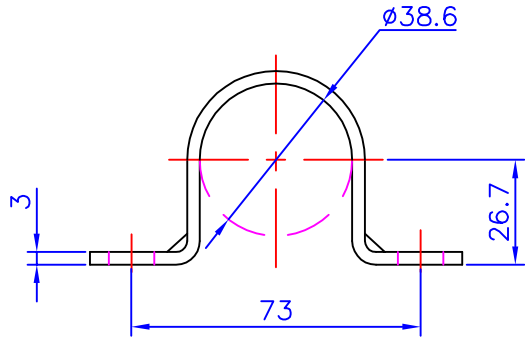

Bearing Bracket Inner S 小托架 (内)
CIMC-D23-06

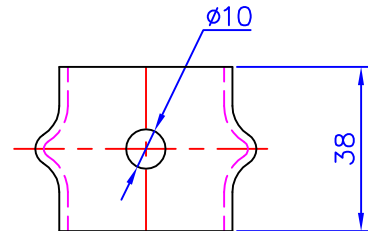
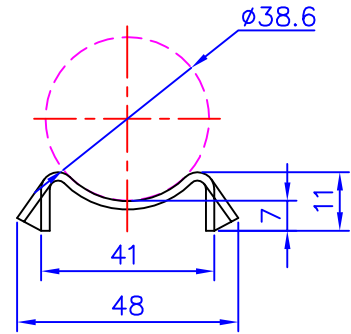

TITLE	Bearing Bracket S 小托架外/内	WEIGHT	0.120/0.030 KGS		
SPEC		MATERIAL	SS400/Q235B		
PART NO.	CIMC-D23-05/06	UNIT	mm	PAGE NO.	35

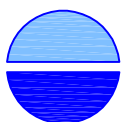

CIMC

CIMC-D23-07A
 Forging Type 花式

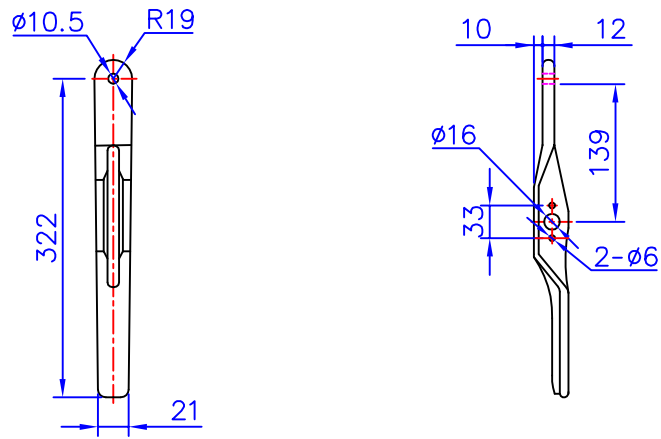

CIMC-D23-07B
 Press Type 平式

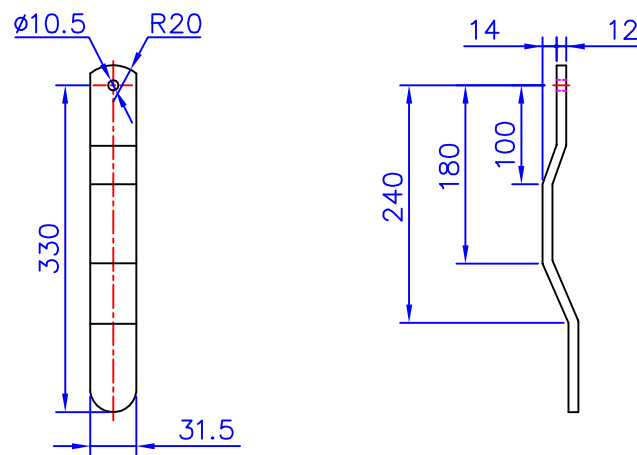

CIMC-D23-07C
 Forging Type (Without Hole)
 花式无孔

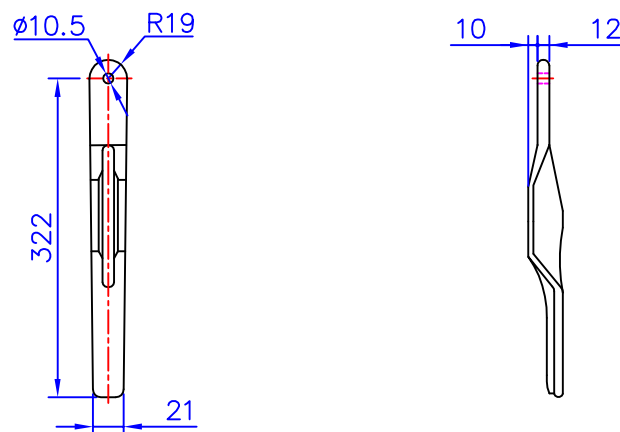

TITLE	Handle 手柄	WEIGHT	0.870/0.980/0.870 KGS		
SPEC		MATERIAL	SS400/Q235B		
PART NO.	CIMC-D23-07A/B/C	UNIT	mm	PAGE NO.	36

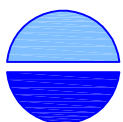

CIMC

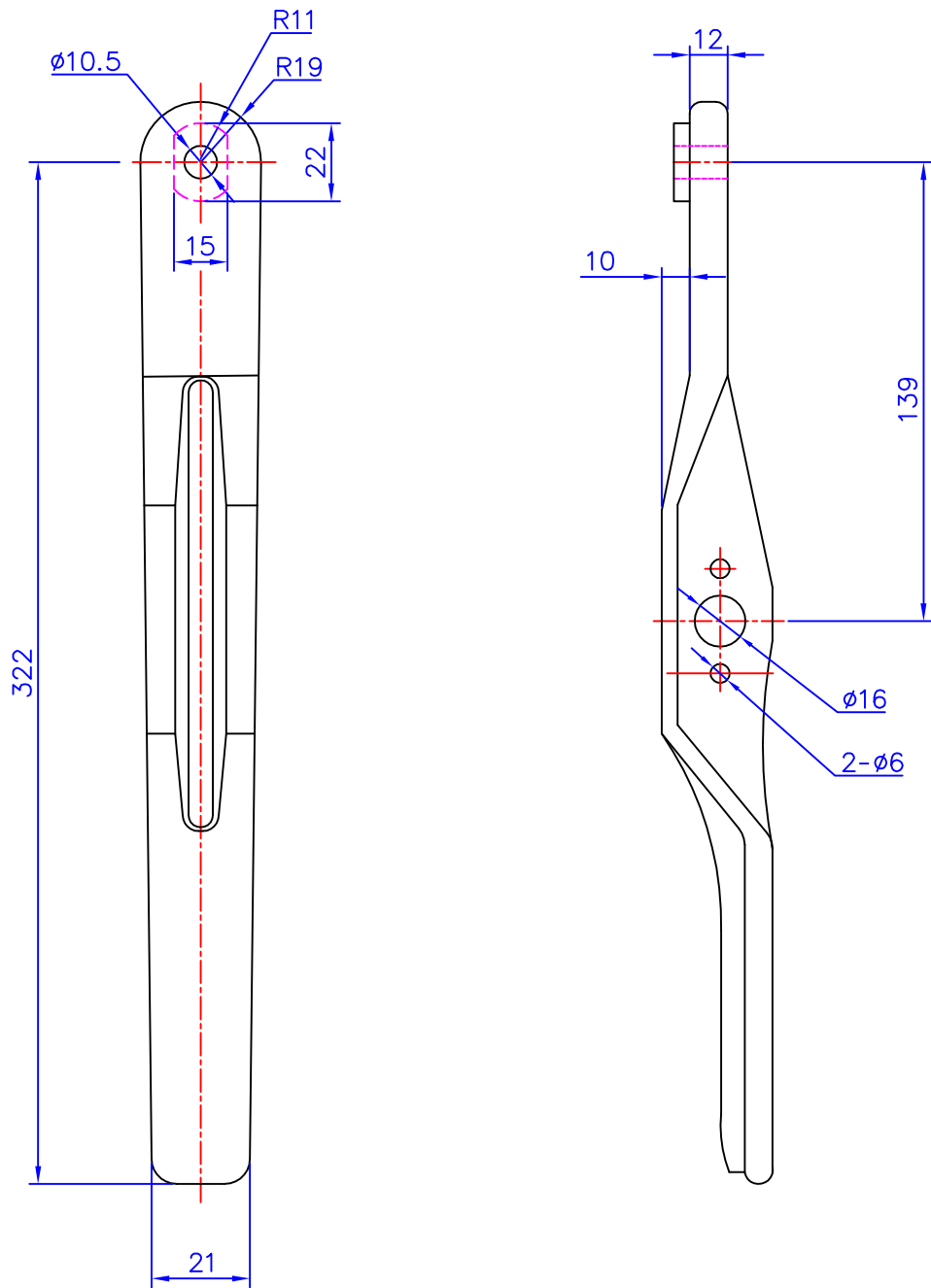

TITLE	Handle ET型防盗手柄	WEIGHT	0.840 KGS		
SPEC	ET Security Type	MATERIAL	SS400/Q235B		
PART NO.	CIMC-D23-07E	UNIT	mm	PAGE NO.	37

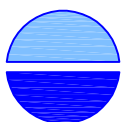

CIMC

CIMC-D23-08A
 Forging Type
 配花式门手柄

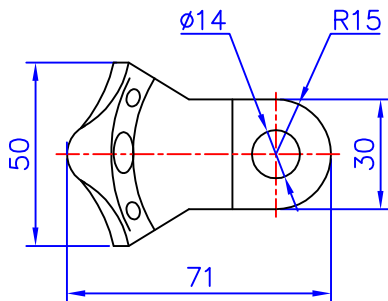
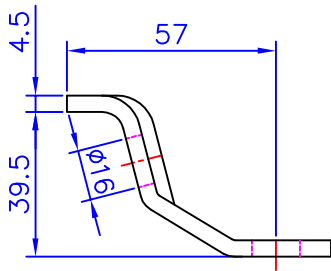

CIMC-D23-08B
 Press Type
 配平式门手柄

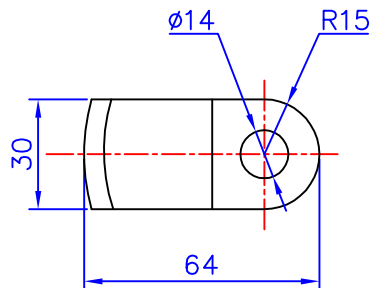
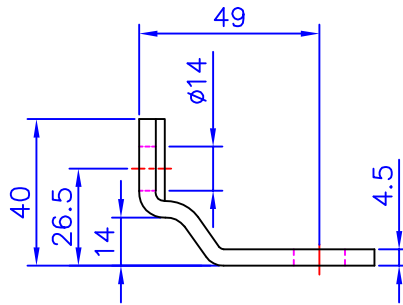

CIMC-D23-08C
 Forging Type (Without Hole)
 配花式无孔门手柄

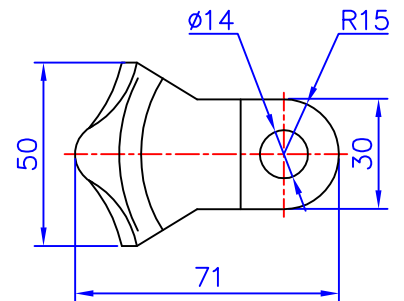
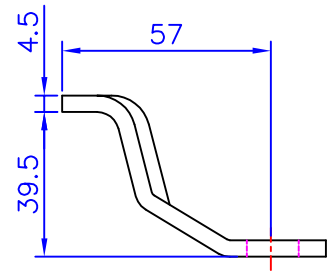

TITLE	Retainer Catch 托架盖	WEIGHT	0.090/0.078/0.088 KGS		
SPEC		MATERIAL	SS400/Q235B		
PART NO.	CIMC-D23-08A/B/C	UNIT	mm	PAGE NO.	38

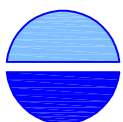

CIMC

CIMC-D23-09A
 Forging Type
 配花式门手柄

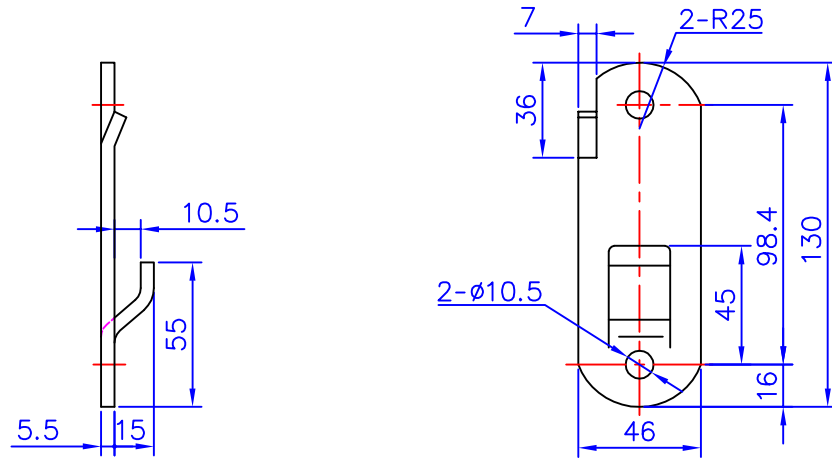

CIMC-D23-09B
 Press Type
 配平式门手柄

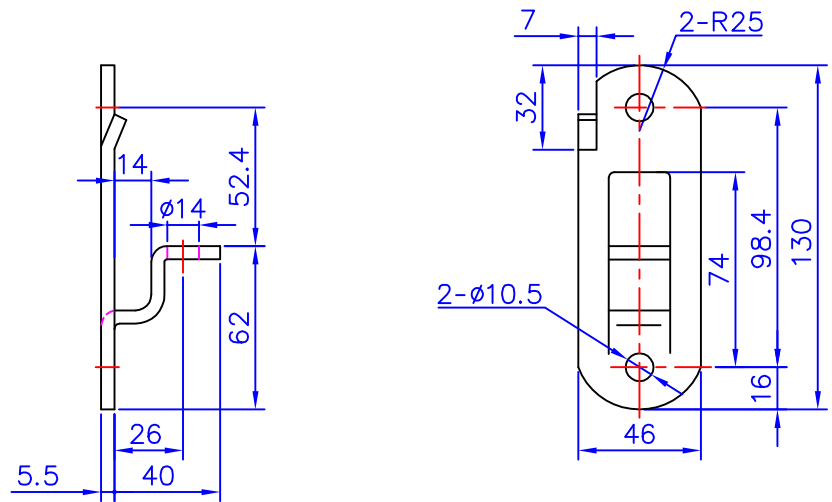

CIMC-D23-09C
 Forging Type (Without Hole)
 配花式无孔门手柄

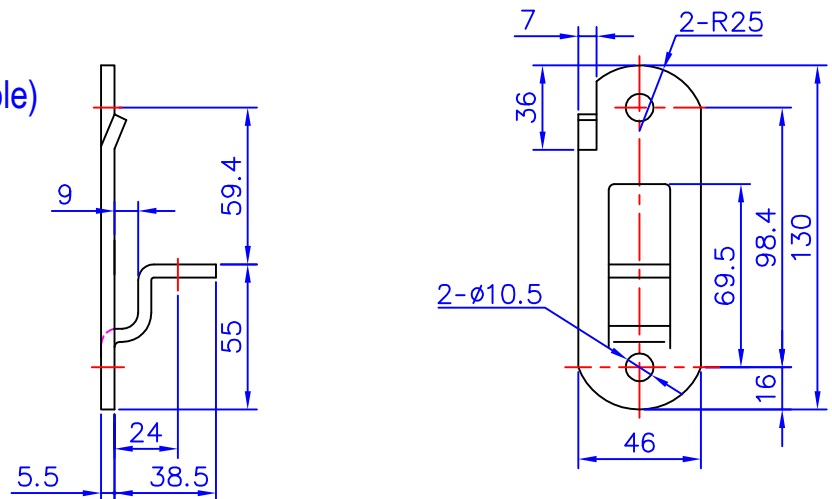

TITLE	Retainer Plate 托架座	WEIGHT	0.020/0.196/0.196 KGS		
SPEC		MATERIAL	SS400/Q235B		
PART NO.	CIMC-D23-09A/B/C	UNIT	mm	PAGE NO.	39

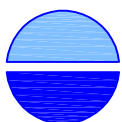

CIMC

CIMC-D23-10
Bush 杯型垫圈

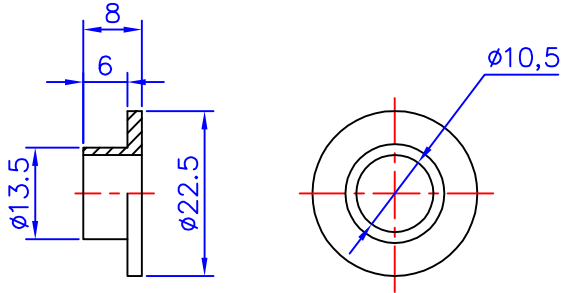

CIMC-D23-11
Handle Hub 扳手座

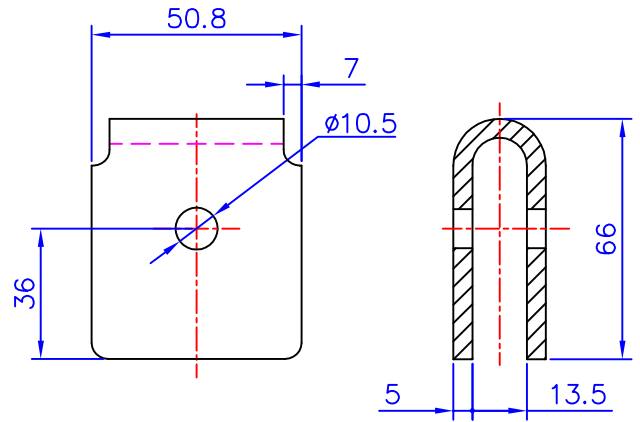

CIMC-D23-12
River 把手铆钉

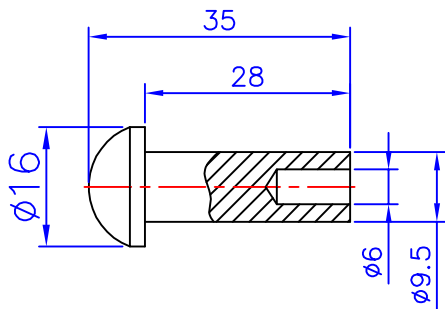

CIMC-D23-13
Anti-Rack Ring 定位环

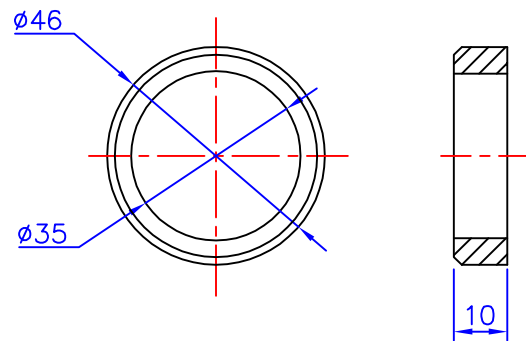

TITLE	Door Hardware 门锁零件	WEIGHT	0.007/0.178/0.022/0.058 KGS		
SPEC		MATERIAL	SS400/Q235B		
PART NO.	CIMC-D23-10/11/12/13	UNIT	mm	PAGE NO.	40

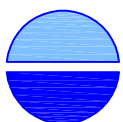

CIMC

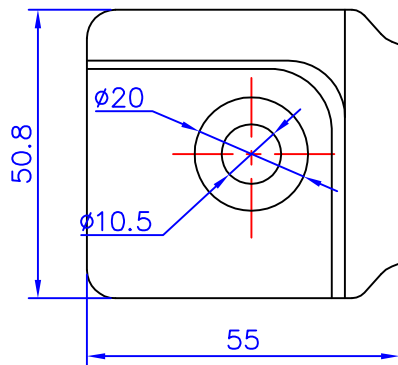
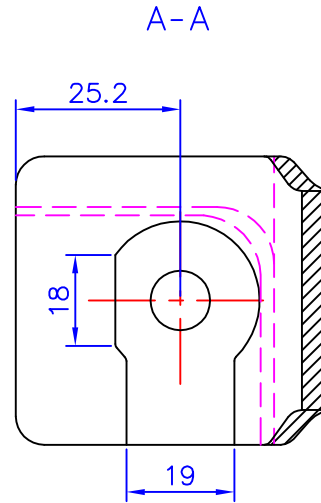
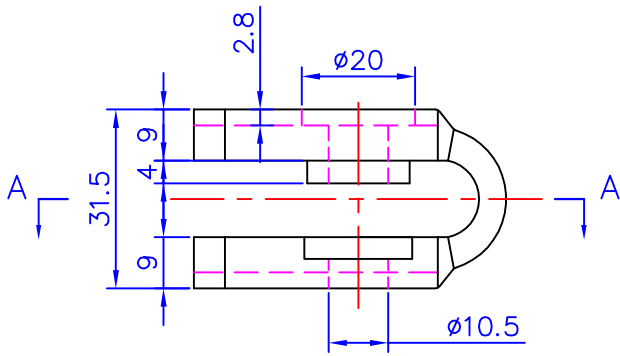

PART NO.	SPEC	WEIGHT
CIMC-D23-11E	Handle Hub ET型防盗扳手座	0.250

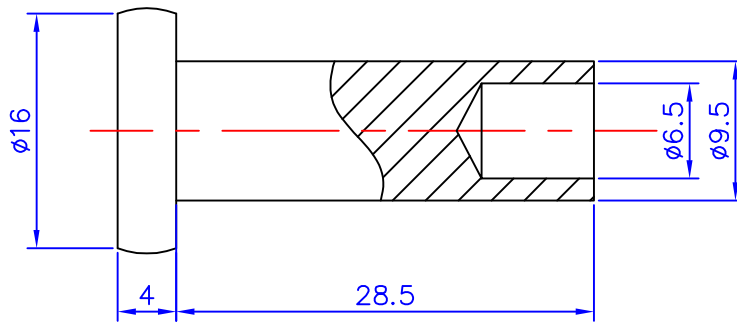

PART NO.	SPEC	WEIGHT
CIMC-D23-12E	Rivet ET型不锈钢铆钉	0.022

TITLE	ET型	WEIGHT	KGS		
SPEC		MATERIAL	SS400 & SUS304		
PART NO.	CIMC-D23-11E/12E	UNIT	mm	PAGE NO.	41

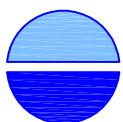

CIMC

CIMC-D23-14

Upper Short Split Bush 塑料衬套凸

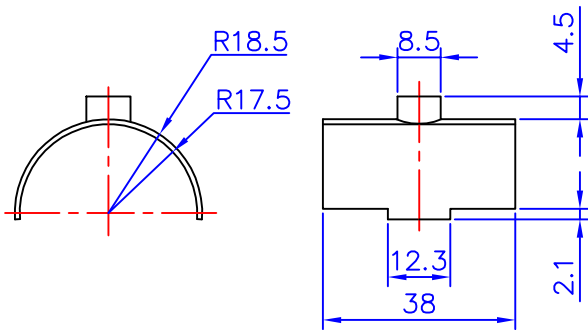

CIMC-D23-15

Lower Short Split Bush 塑料衬套凹

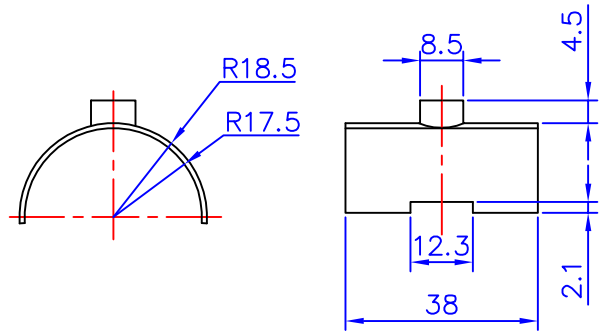

CIMC-D23-16

Split Large Bush 大衬套

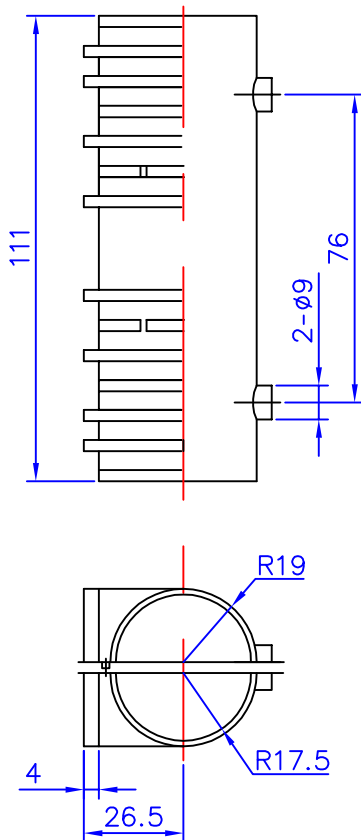

CIMC-D23-17

Split Small Bush 小衬套

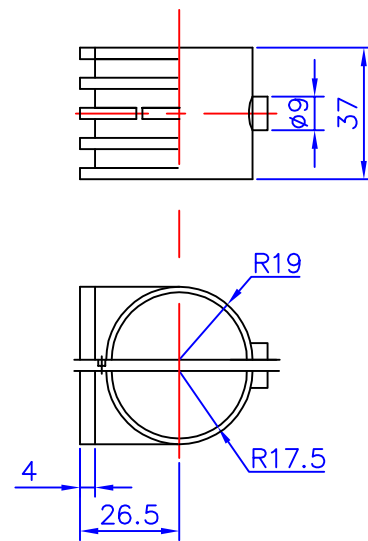

TITLE	Split Bush 衬套	WEIGHT	0.001/0.001/0.010/0.005KGS		
SPEC		MATERIAL	Nylon		
PART NO.	CIMC-D23-14/15/16/17	UNIT	mm	PAGE NO.	42

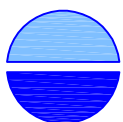

CIMC

CIMC-D24-01
Froging Type

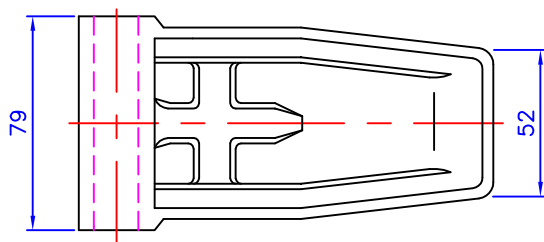
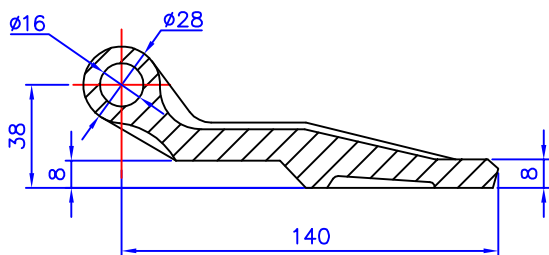

CIMC-D24-02
Welding Type

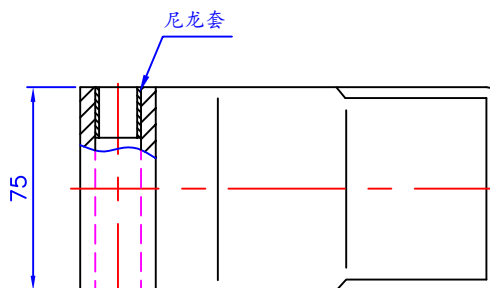
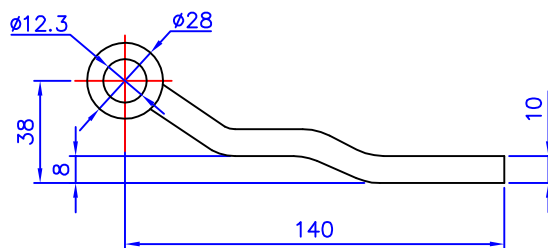

CIMC-D24-03
Welding Type

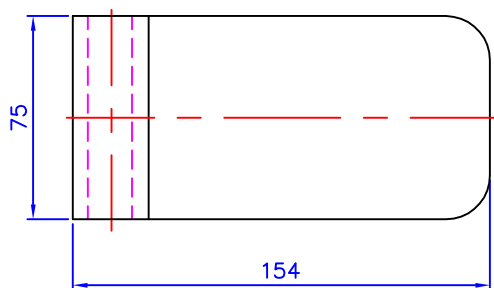
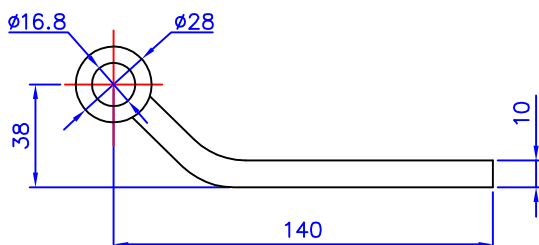

CIMC-D24-04
Maersk Type

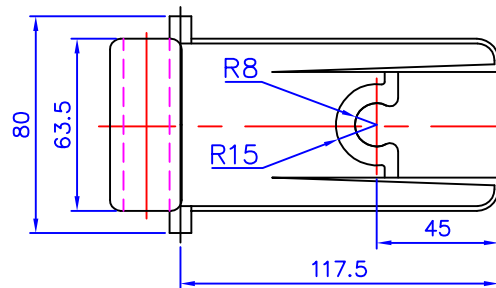
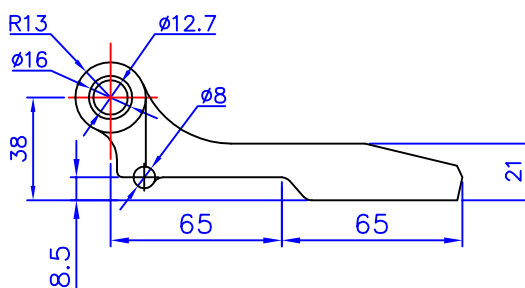

TITLE	Hinge Blade 门铰链	WEIGHT	1.450/1.010/0.990/1.000 KGS		
SPEC		MATERIAL	SS400/Q235B		
PART NO.	CIMC-D24-01/02/03/04	UNIT	mm	PAGE NO.	43

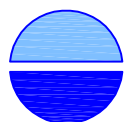

CIMC

CIMC-D24-05
Hinge Pin 不锈钢插销
Material: SUS201

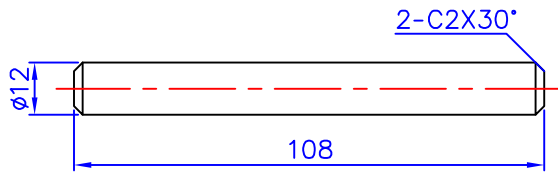

CIMC-D24-07
Brass Wash 铜垫片
Material: Brass

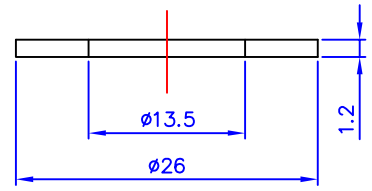

CIMC-D24-06
Hinge Lug 小吊耳
Material: SS400

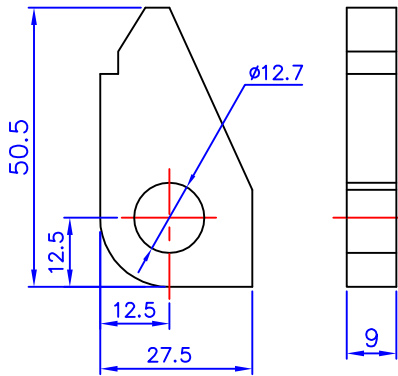

CIMC-DGE07040
Small Bracket Gasket
通用箱小托架垫 (4MM厚)

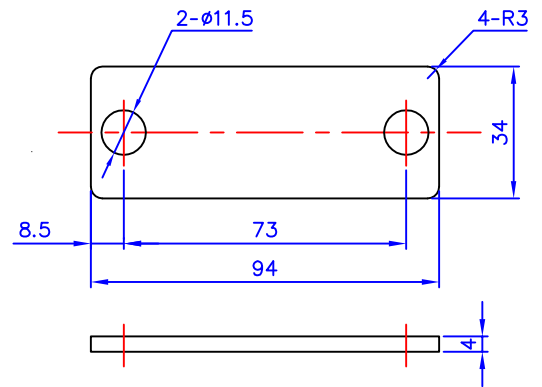

CIMC-DGE06
Large Bracket Gasket
大托架垫

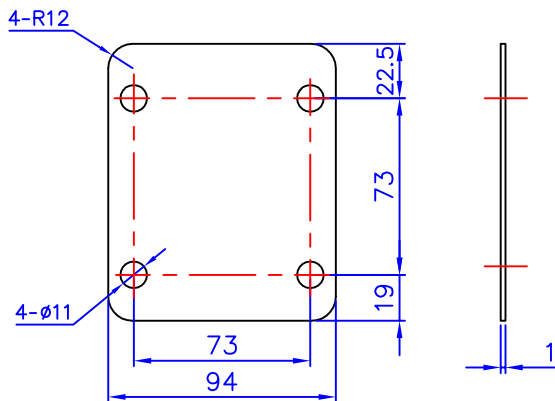

CIMC-DGE08040
Retainer Bracket Gasket
通用箱手柄托架垫 (4MM厚)

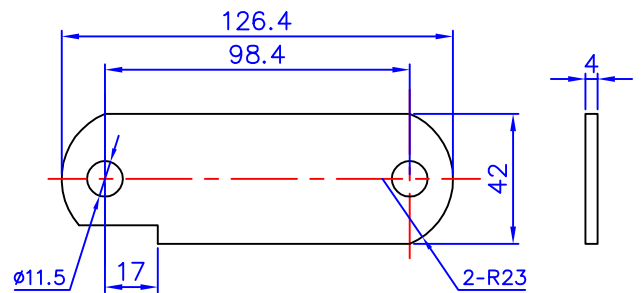

TITLE	Accessory 配件	WEIGHT	KGS		
SPEC		MATERIAL			
PART NO.	CIMC-D24-05/06/07 CIMC-DGE	UNIT	mm	PAGE NO.	44

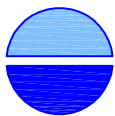

CIMC

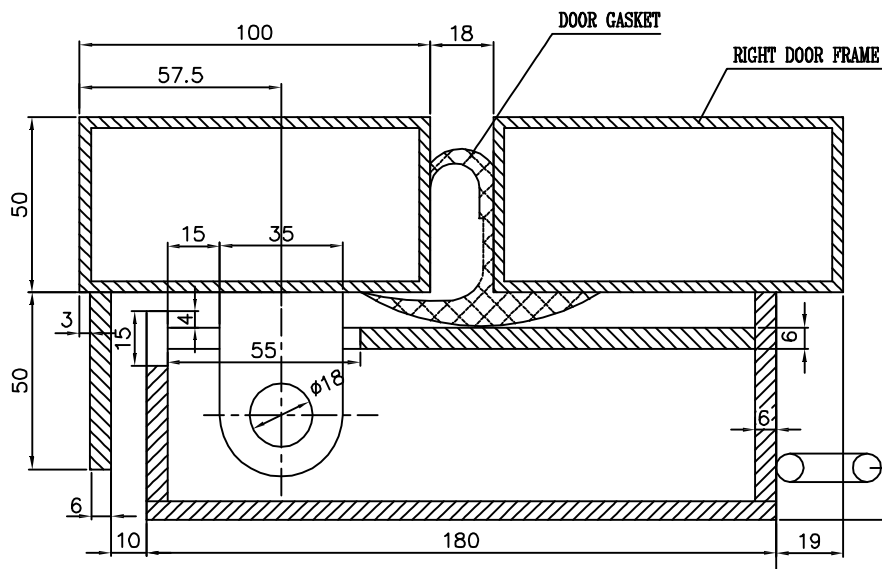
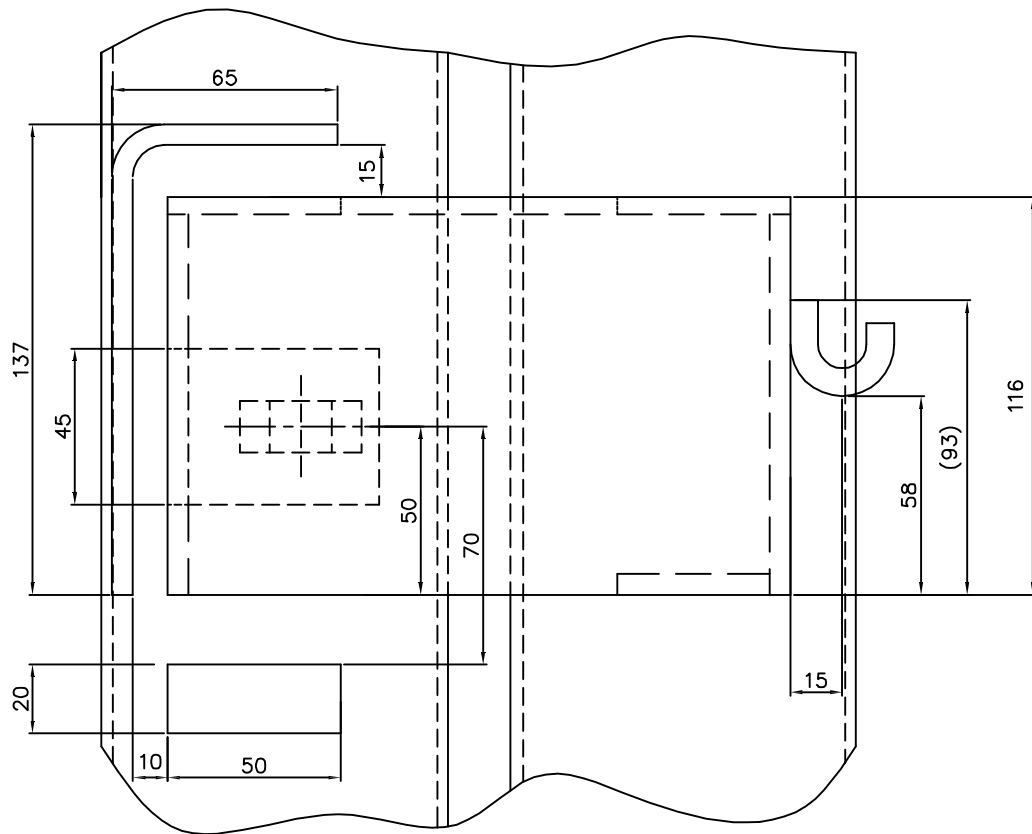

TITLE	Lock Box 锁盒	WEIGHT	KGS		
SPEC		MATERIAL			
PART NO.	CIMC-D24-10	UNIT	mm	PAGE NO.	45

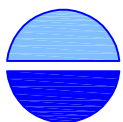

CIMC

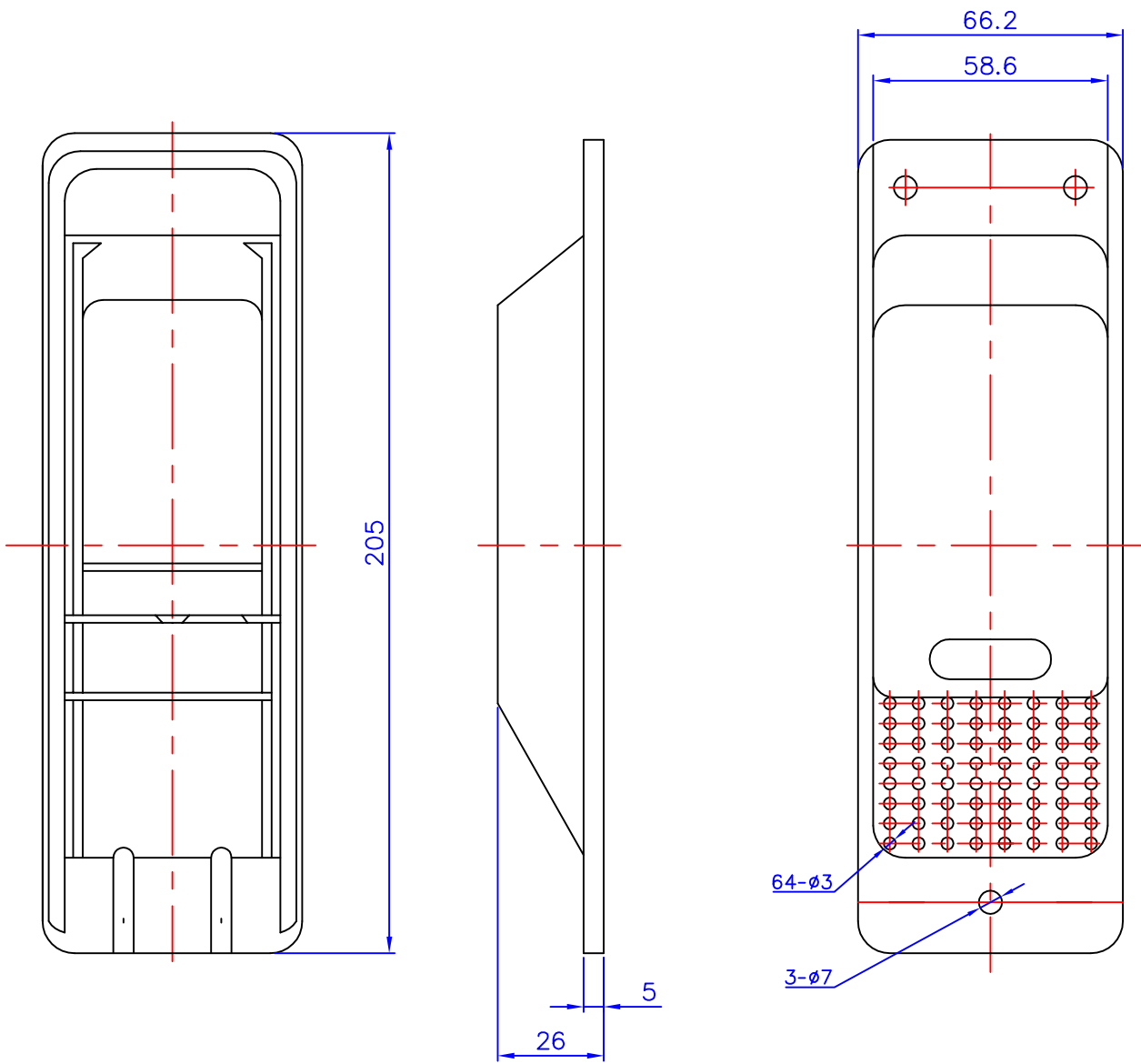

TITLE	Ventilator 小通风器	WEIGHT	0.070 KGS		
SPEC	"S" Type	MATERIAL			
PART NO.	CIMC-D25-01	UNIT	mm	PAGE NO.	46



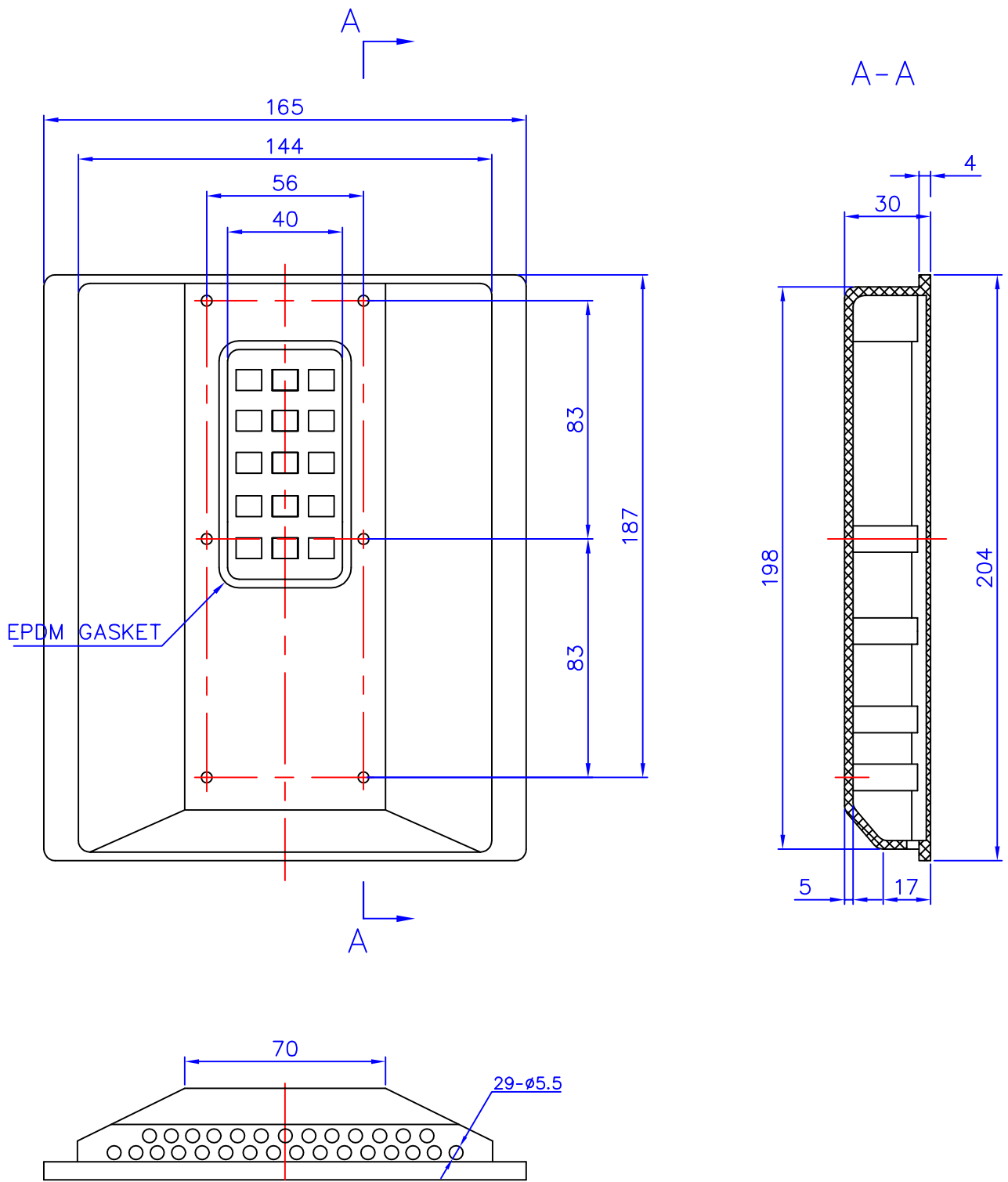

TITLE	Ventilator 大通风器	WEIGHT	0.300 KGS		
SPEC	"M" Type	MATERIAL	ABS		
PART NO.	CIMC-D25-02	UNIT	mm	PAGE NO.	47

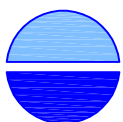

CIMC

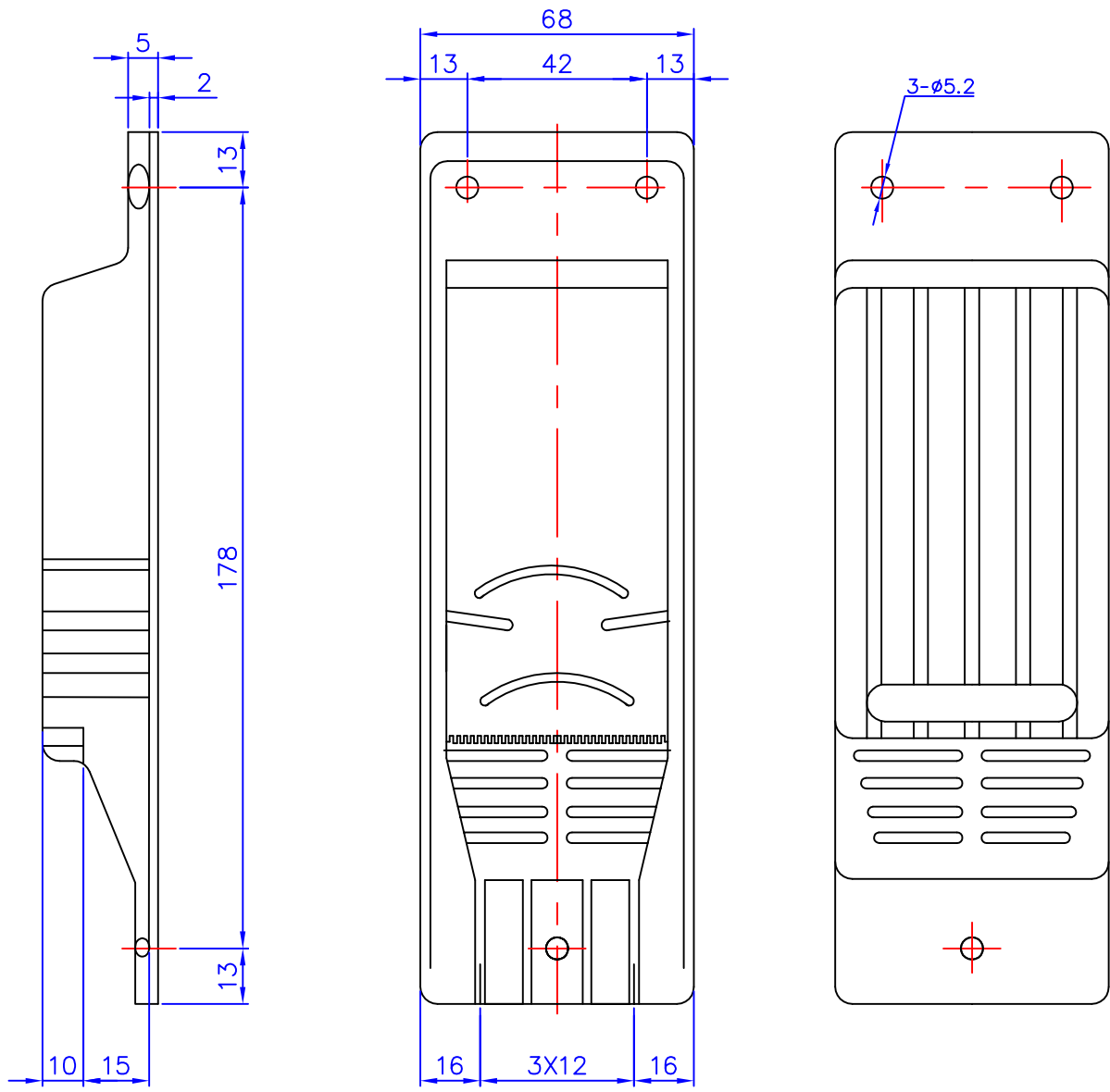

TITLE	Ventilator 小通风器	WEIGHT	0.070 KGS		
SPEC	"TAL" Type	MATERIAL	ABS		
PART NO.	CIMC-D25-03	UNIT	mm	PAGE NO.	48



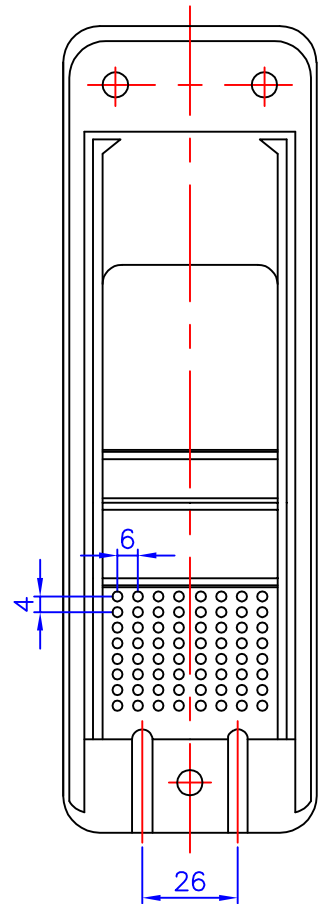
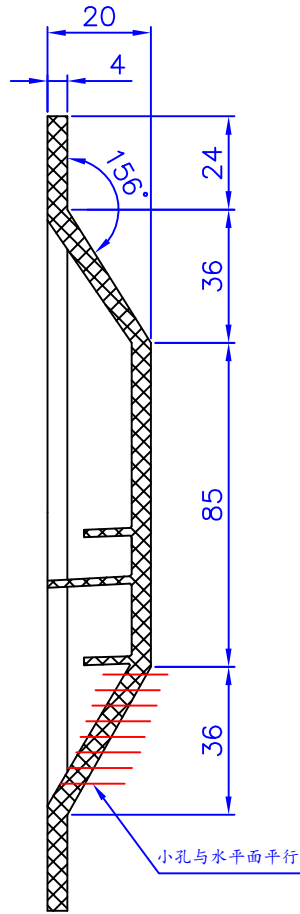
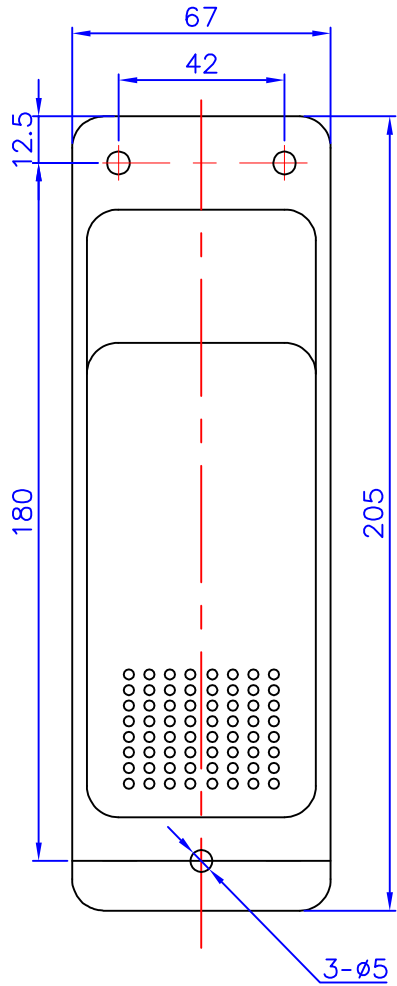

TITLE	Ventilator 通风盖	WEIGHT	0.070 KGS		
SPEC	For Pallet Wide Container	MATERIAL	ABS		
PART NO.	CIMC-D25-04	UNIT	mm	PAGE NO.	49

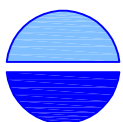

CIMC

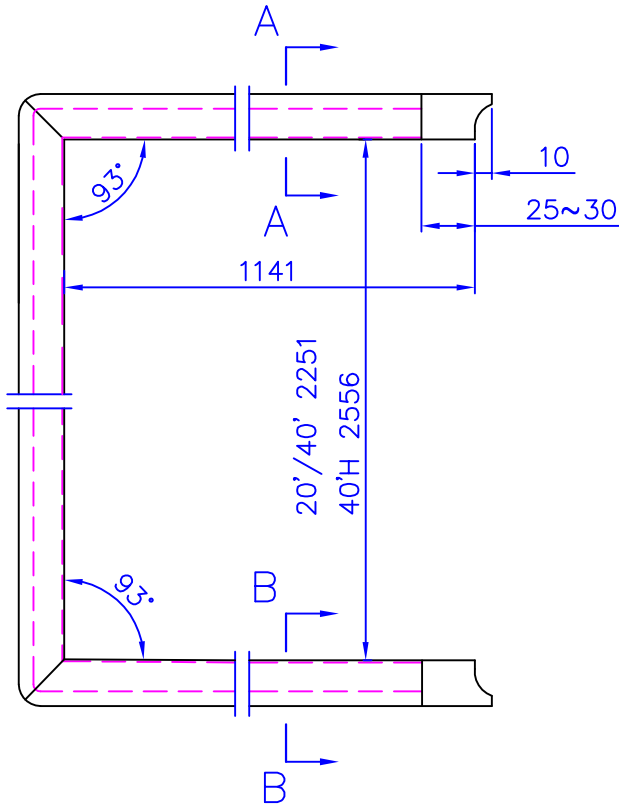

Left Hand Door Only

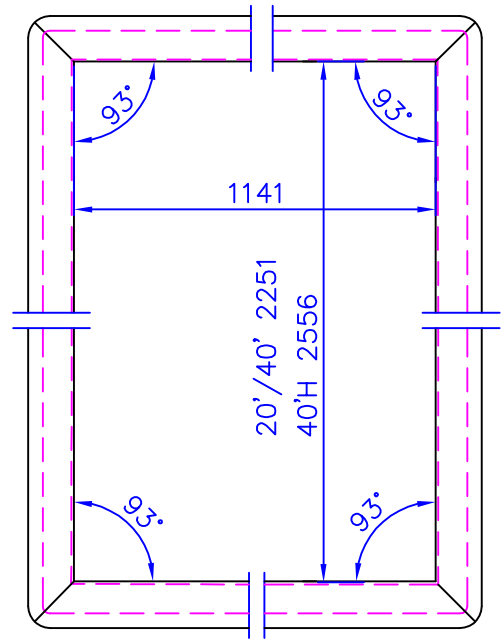

Right Hand Door Only

A-A
5:1

B-B
5:1

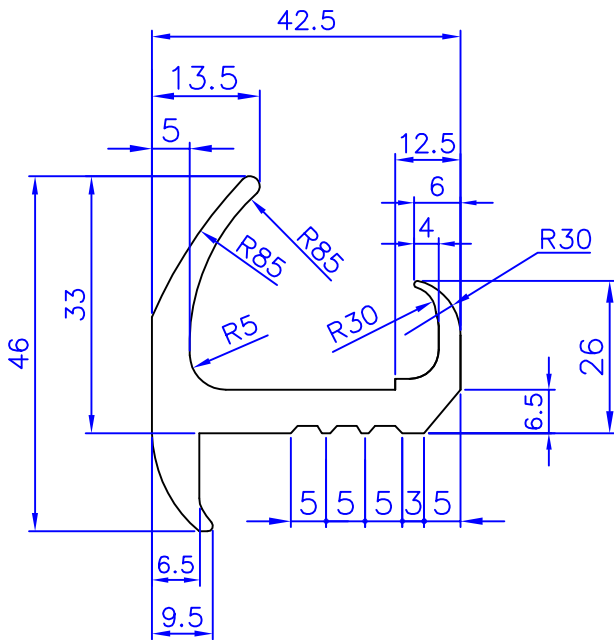

For Upper & Side

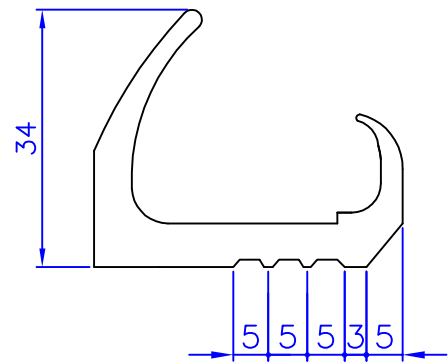

For Lower Only

PART NO.	SPEC	WEIGHT
CIMC-D26-01A	Container Set , 20'/40'	6.000
CIMC-D26-01B	Container Set , 40HC	8.000

TITLE	Door Seal 门封条	WEIGHT	KGS		
SPEC	"JC" Type	MATERIAL	EPDM		
PART NO.	CIMC-D26-01A/B	UNIT	mm	PAGE NO.	50

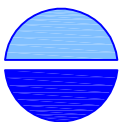

CIMC

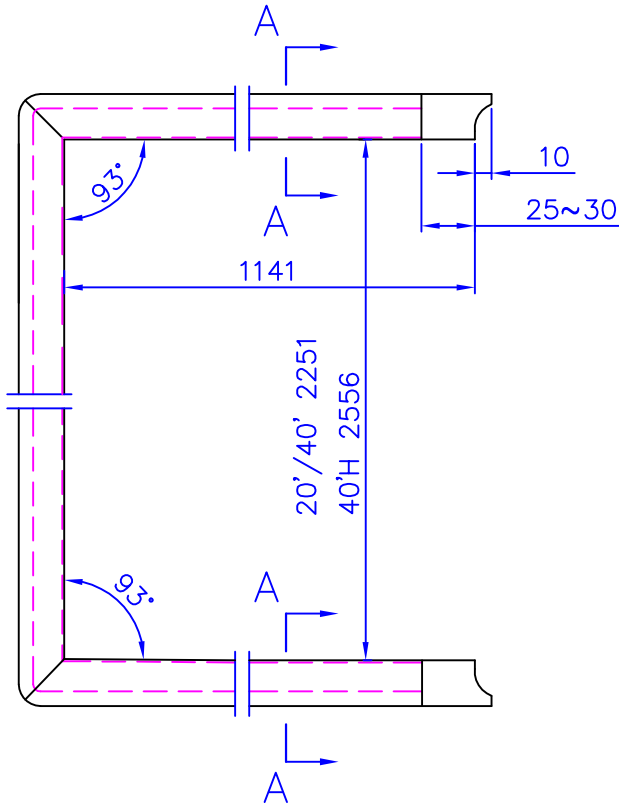

Left Hand Door Only

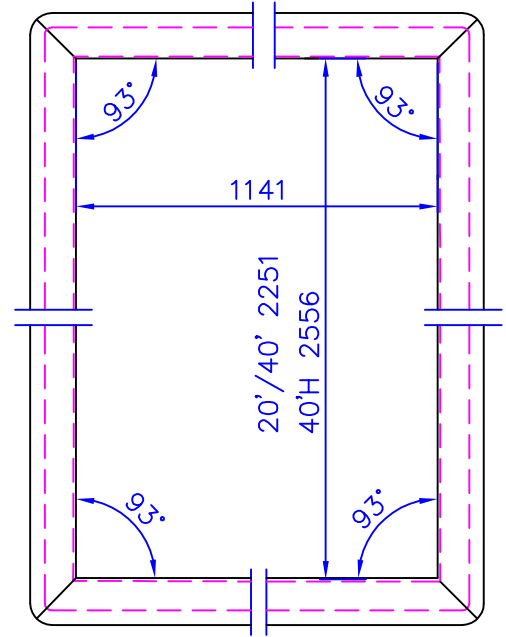

Right Hand Door Only

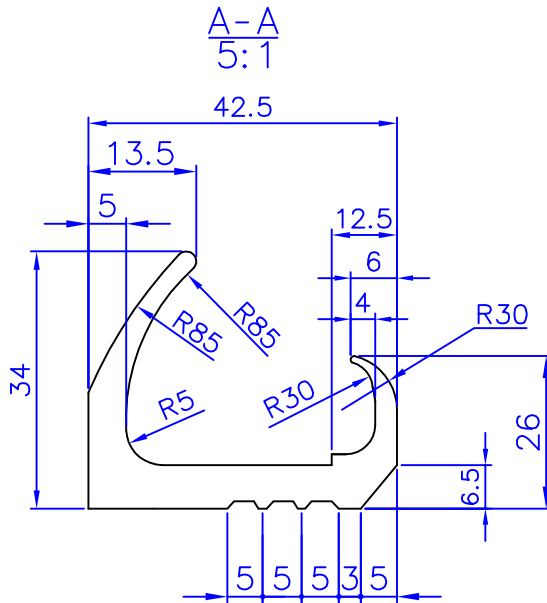

PART NO.	SPEC	WEIGHT
CIMC-D26-01A	Container Set , 20'/40'	6.000
CIMC-D26-01B	Container Set , 40'HC	8.000
CIMC-D26-01C	2.50M/PC	1.500
CIMC-D26-01D	40.00M/ROLL	24.000
CIMC-D26-01E	300mmX300mm/PC	0.600

TITLE	Door Seal 门封条	WEIGHT	KGS		
SPEC	"C" Type	MATERIAL	EPDM		
PART NO.	CIMC-D26-02A/B/C/D/E	UNIT	mm	PAGE NO.	51

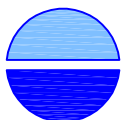

CIMC

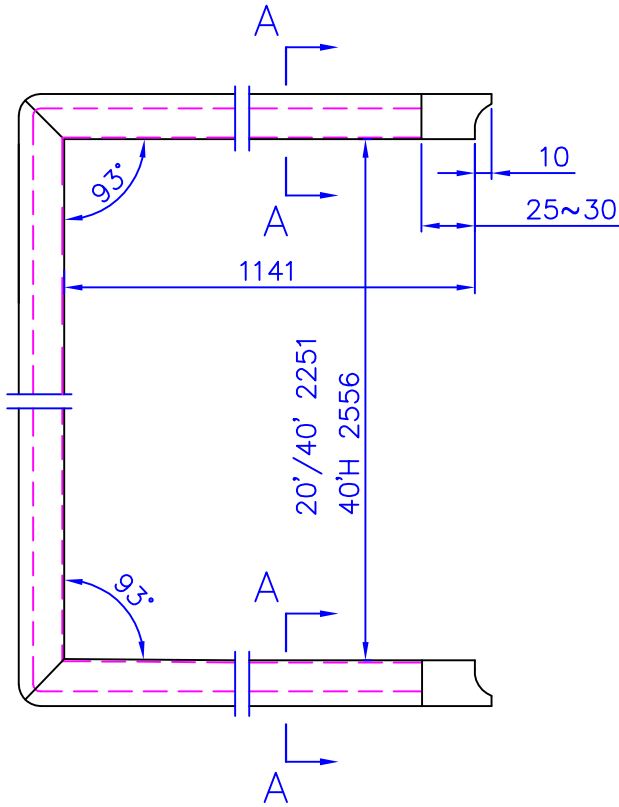

Left Hand Door Only

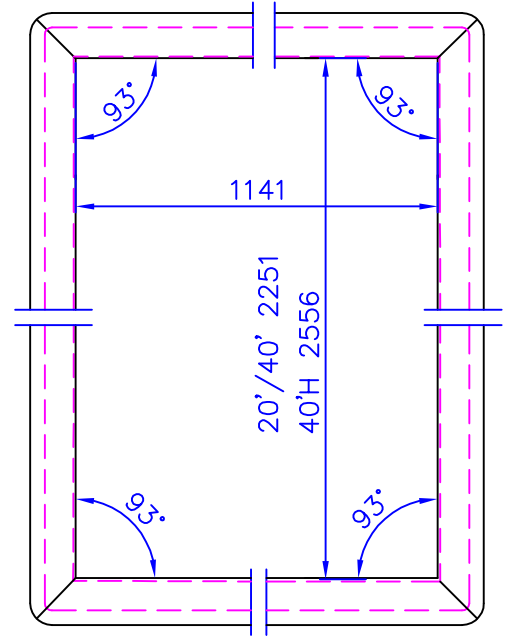

Right Hand Door Only

A-A
5:1

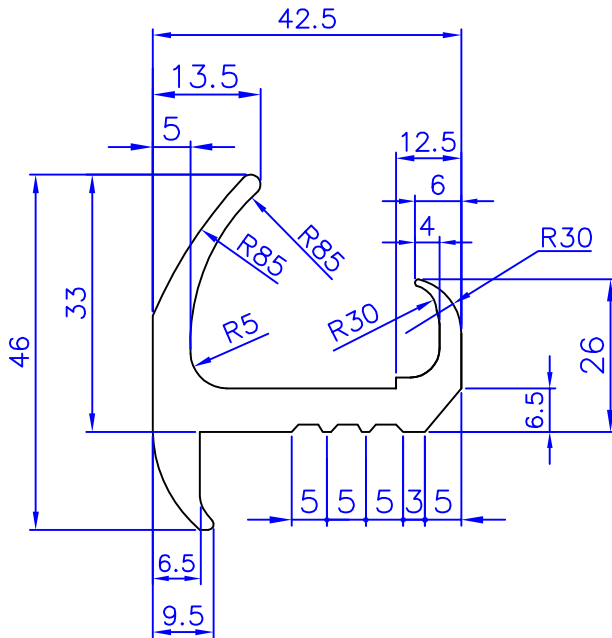

PART NO.	SPEC	WEIGHT
CIMC-D26-03A	Container Set , 20'/40'	6.000
CIMC-D26-03B	Container Set , 40'HC	8.000
CIMC-D26-03C	2.50M/PC	1.500
CIMC-D26-03D	300mmX300mm/PC	0.600
CIMC-D26-01K	1200mmX1200mm/PC	3.000

TITLE	Door Seal 门封条	WEIGHT	KGS		
SPEC	"J" Type	MATERIAL	EPDM		
PART NO.	CIMC-D26-03A/B/C/D/K	UNIT	mm	PAGE NO.	52

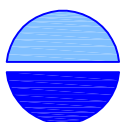

CIMC

CIMC-D27-01
Door Screw M10X25 螺栓

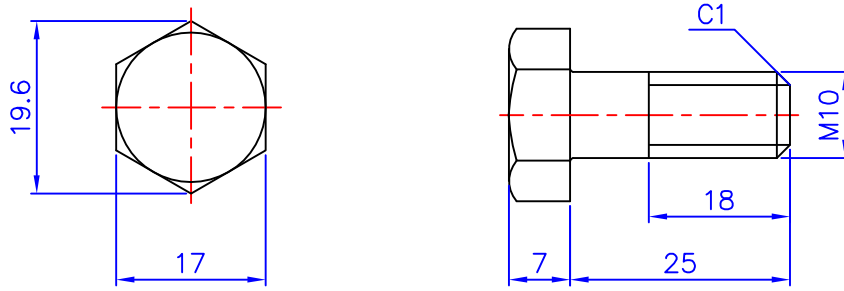

CIMC-D27-02
Door Screw M10X35 螺栓

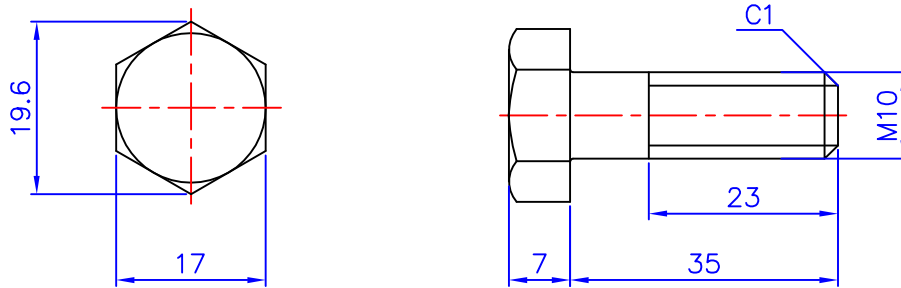

CIMC-D27-03
Door Screw Nut M10 螺母

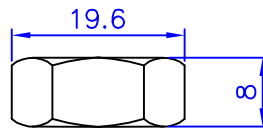

CIMC-D27-04
Door Screw Rubber Ø10 弹簧垫片

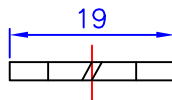

TITLE	Door Screw 门螺丝	WEIGHT	KGS		
SPEC		MATERIAL			
PART NO.	CIMC-D27-01/02/03/04	UNIT	mm	PAGE NO.	53

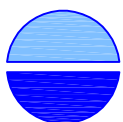

CIMC

Phillips Head 十字槽

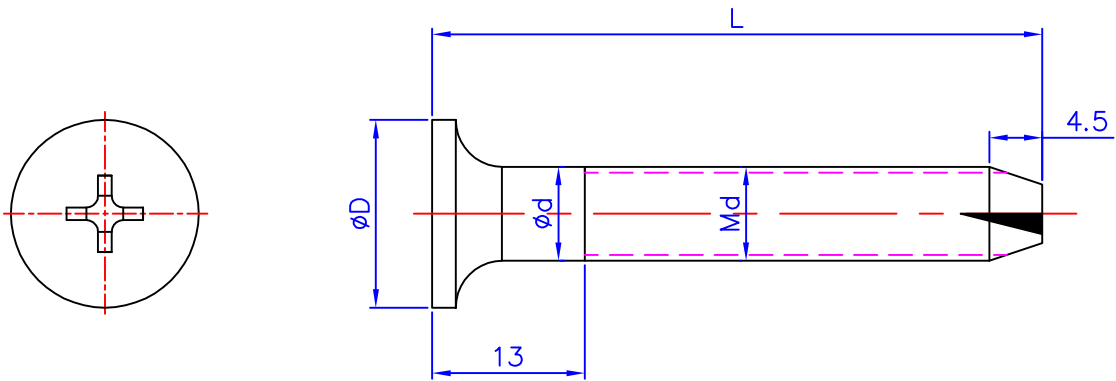

PART NO.	SPEC	L	ØD	Ød
CIMC-D28-01A	M6X45	45	14.5	6
CIMC-D28-01B	M6X50	65	14.5	6
CIMC-D28-01C	M6X65	50	14.5	6
CIMC-D28-02A	M8X45	45	15.5	8
CIMC-D28-02B	M8X50	50	15.5	8
CIMC-D28-02C	M8X65	65	15.5	8

Trox Head 梅花槽

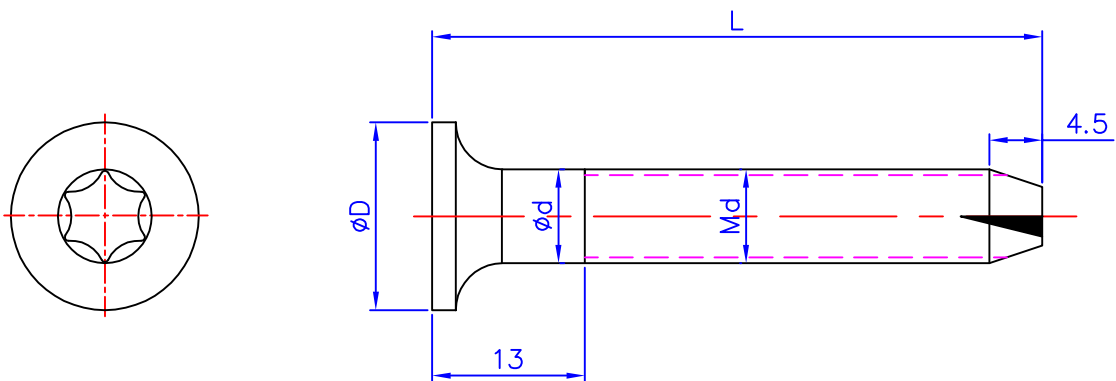

PART NO.	SPEC	L	ØD	Ød
CIMC-D28-02A-1	M8X45	45	15.5	8
CIMC-D28-02B-1	M8X50	50	15.5	8
CIMC-D28-02C-1	M8X65	65	15.5	8

TITLE	Tapping Screw 地板釘	WEIGHT	KGS		
SPEC		MATERIAL			
PART NO.	CIMC-D28-01/02	UNIT	mm	PAGE NO.	54

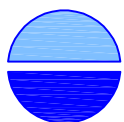

CIMC

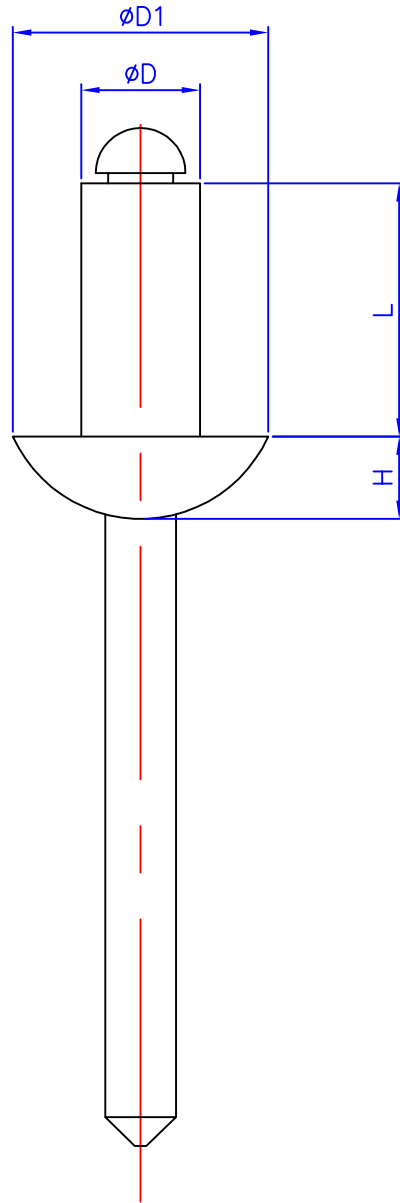

PART NO.	SPEC	H	ØD1	ØD	L
CIMC-D29-01	M4.8X7	1.5	8	4	8
CIMC-D29-02	M4.8X14	1.6	9.5	4.8	14
CIMC-D29-03	M4.8X16.7	1.6	9.5	4	16.7

TITLE	Stainless Blind Rivet 不锈钢拉铆钉	WEIGHT	KGS		
SPEC		MATERIAL	Stainless Steel		
PART NO.	CIMC-D29-01/02/03	UNIT	mm	PAGE NO.	55

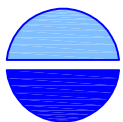

CIMC

CIMC-D30-01
 Ø8X70 For Door

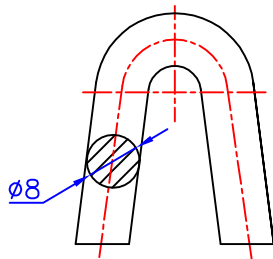

CIMC-D30-02
 Ø12X140 For Front Corner Post

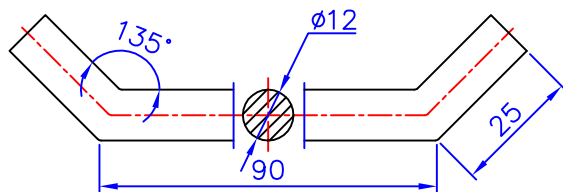

CIMC-D30-03
 Ø12X140 For Top and Bottom Side Rail

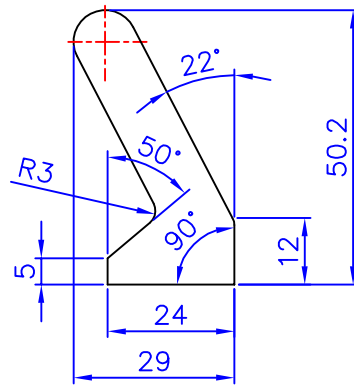
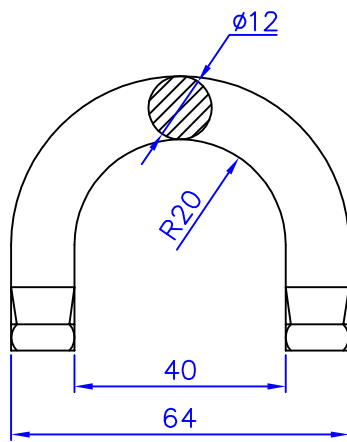

CIMC-D30-06
 Ø6X44

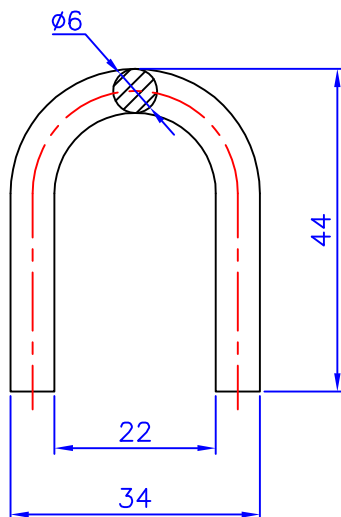

CIMC-D30-05
 Ø12X58 For Rear Corner Post
 Post Lashing Bar

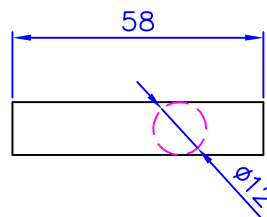

TITLE	Lashing Ring / Bar 绳钩	WEIGHT	KGS		
SPEC		MATERIAL	SS41		
PART NO.	CIMC-D30	UNIT	mm	PAGE NO.	56

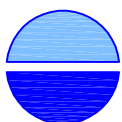

CIMC

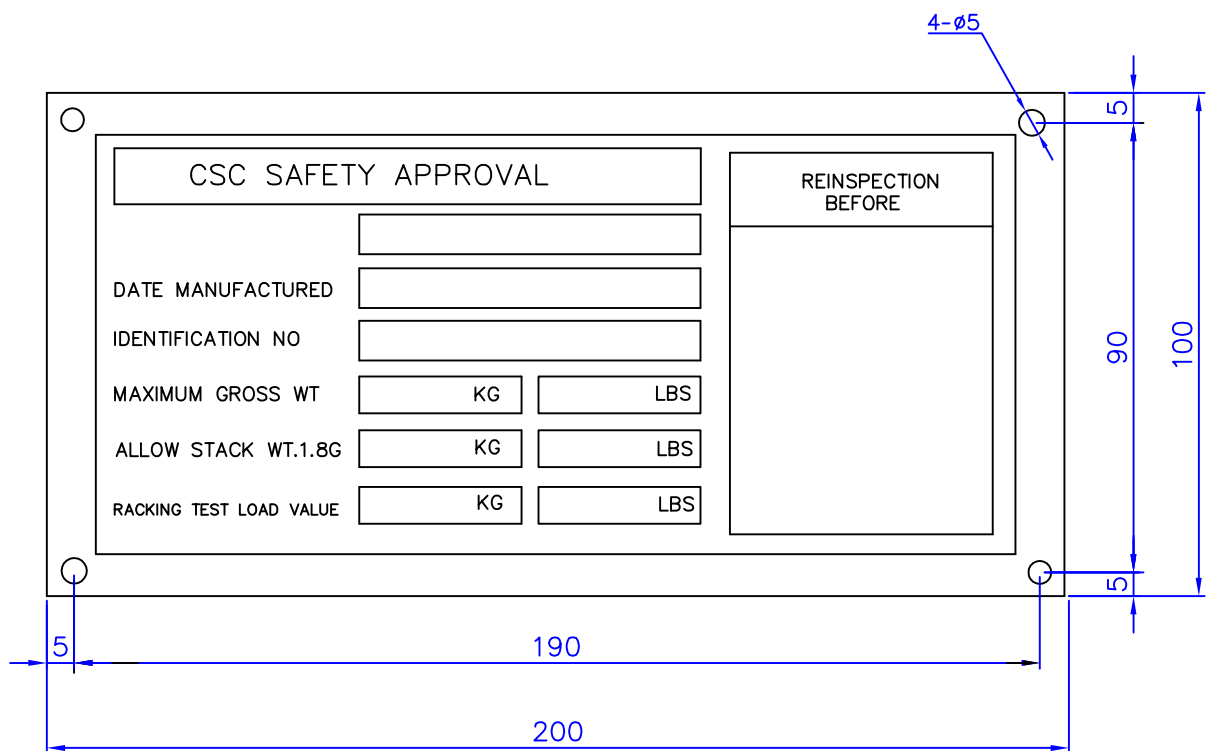

TITLE	CSC Plate 铭牌	WEIGHT	0.130 KGS		
SPEC	0.8X100X200	MATERIAL	Stainless Steel		
PART NO.	CIMC-D31-01	UNIT	mm	PAGE NO.	57

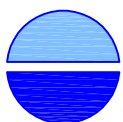

CIMC

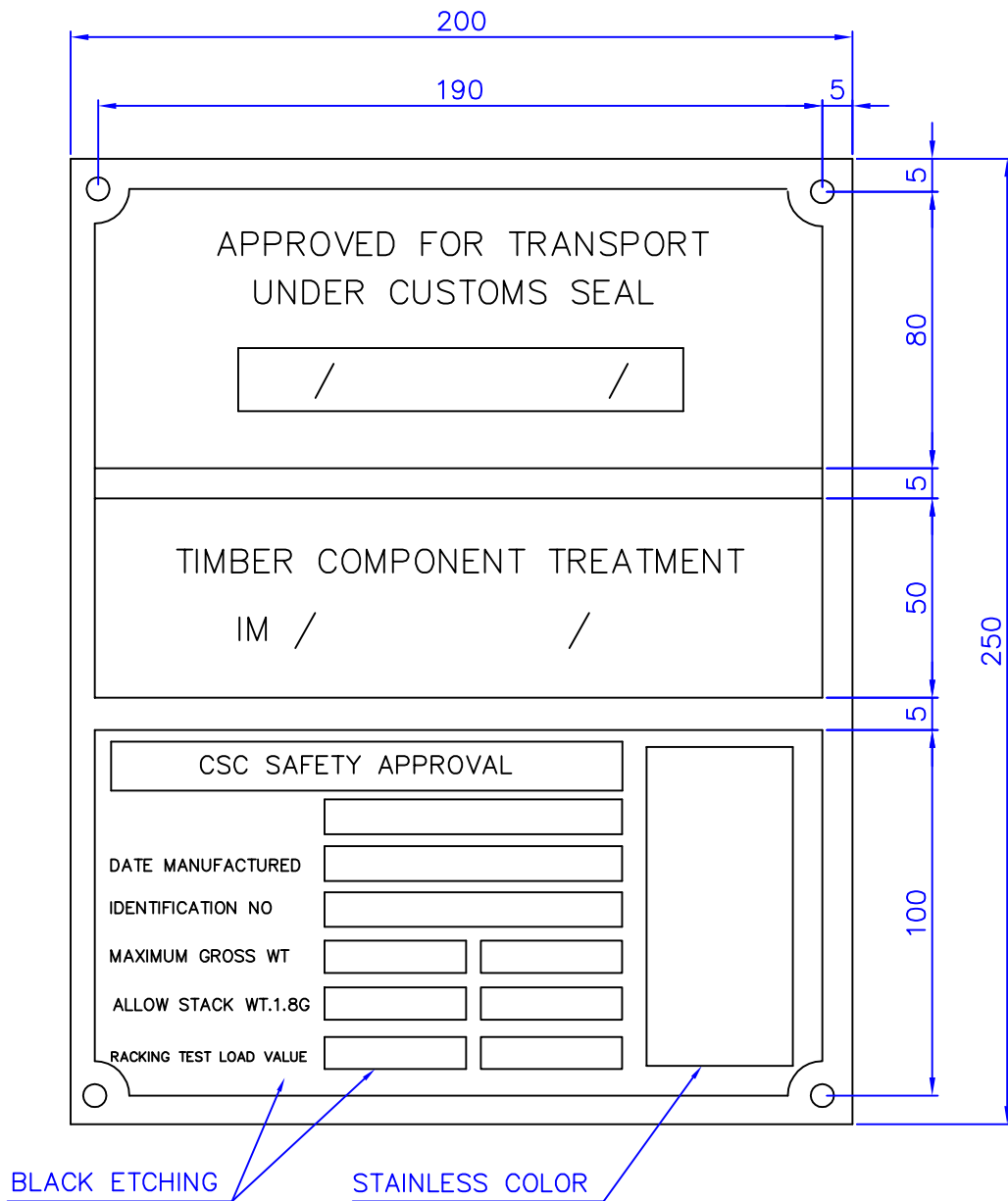

TITLE	CSC Plate 铭牌	WEIGHT	0.320 KGS		
SPEC	0.8X200X250	MATERIAL	Stainless Steel		
PART NO.	CIMC-D31-02	UNIT	mm	PAGE NO.	58

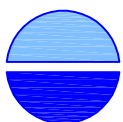

CIMC

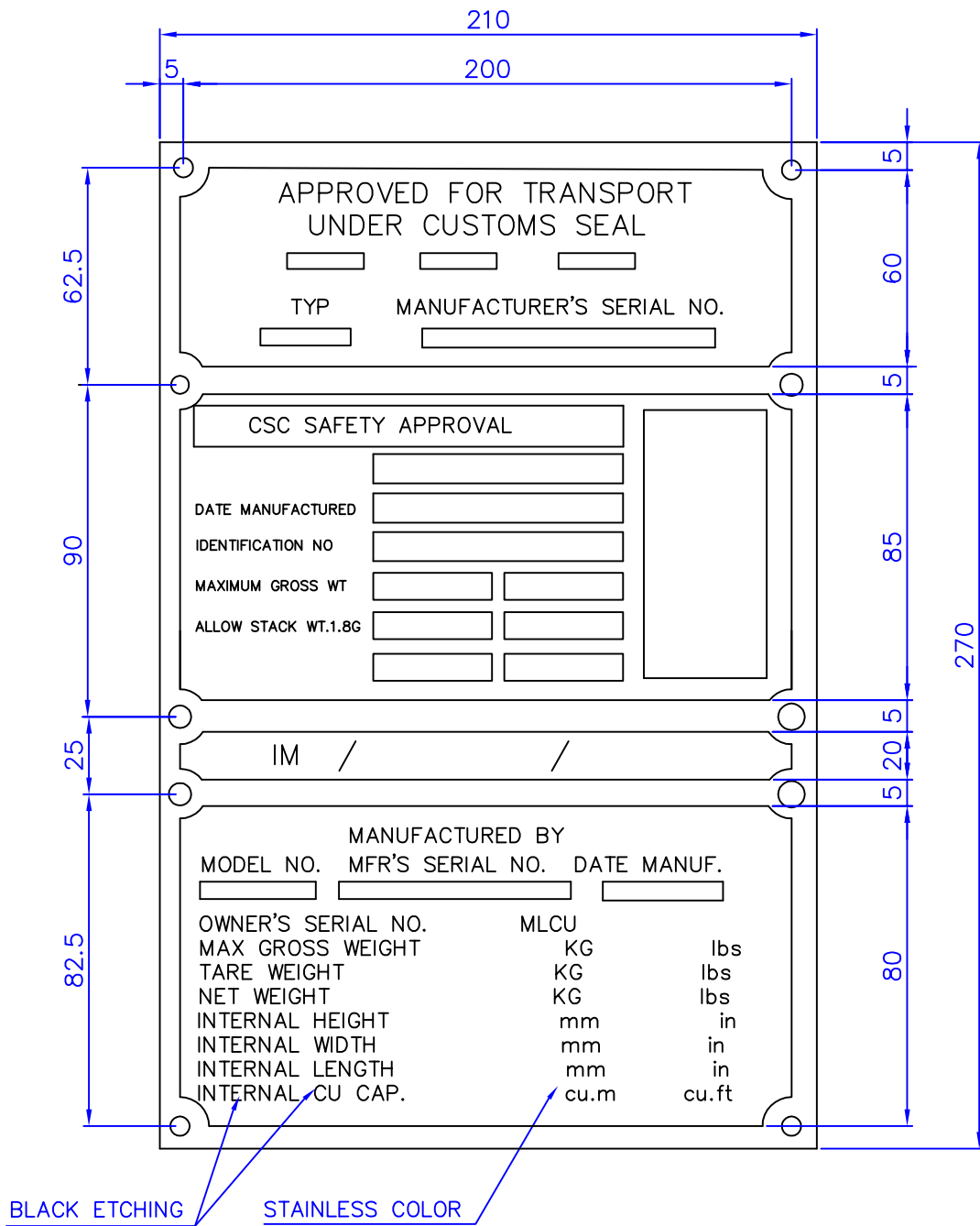

TITLE	CSC Plate 铭牌	WEIGHT	0.360 KGS		
SPEC	0.8X210X270	MATERIAL	Stainless Steel		
PART NO.	CIMC-D31-03	UNIT	mm	PAGE NO.	59

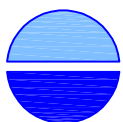

CIMC

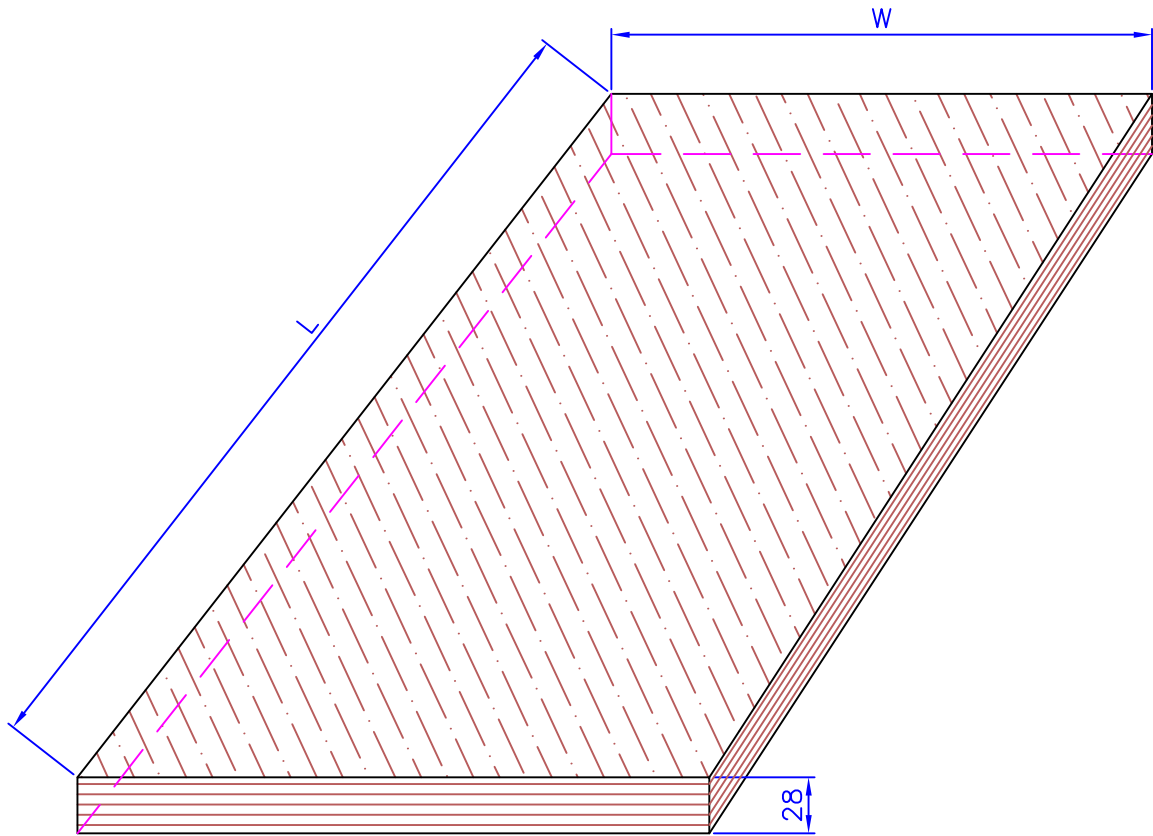

Free chamfer service is available upon request

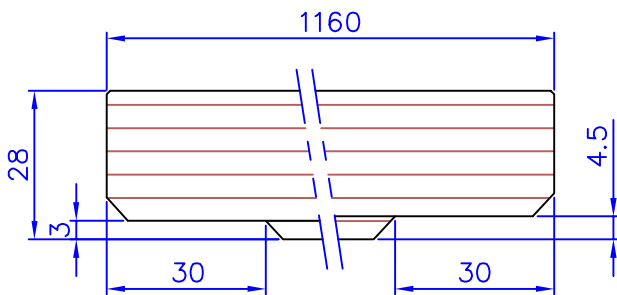

GRADE	PART NO.	SIZE	Working Load in Test (kgs)
Grade H	CIMC-D32-01A-GH	28X1160X2400	7260
	CIMC-D32-01B-GH	28X640X2400	
	CIMC-D32-01C-GH	28X1220X2400	
Grade A	CIMC-D32-01A-GA	28X1160X2400	6000
	CIMC-D32-01B-GA	28X640X2400	
	CIMC-D32-01C-GA	28X1220X2400	
Grade B	CIMC-D32-01A-GB	28X1160X2400	5000
	CIMC-D32-01B-GB	28X640X2400	
	CIMC-D32-01C-GB	28X1220X2400	
Grade C	CIMC-D32-01A-GC	28X1160X2400	4500
	CIMC-D32-01B-GC	28X640X2400	
	CIMC-D32-01C-GC	28X1220X2400	

TITLE	Wooden Flooring 木地板	WEIGHT	KGS		
SPEC		MATERIAL			
PART NO.	CIMC-D32-01	UNIT	mm	PAGE NO.	60

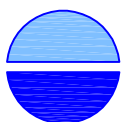

CIMC

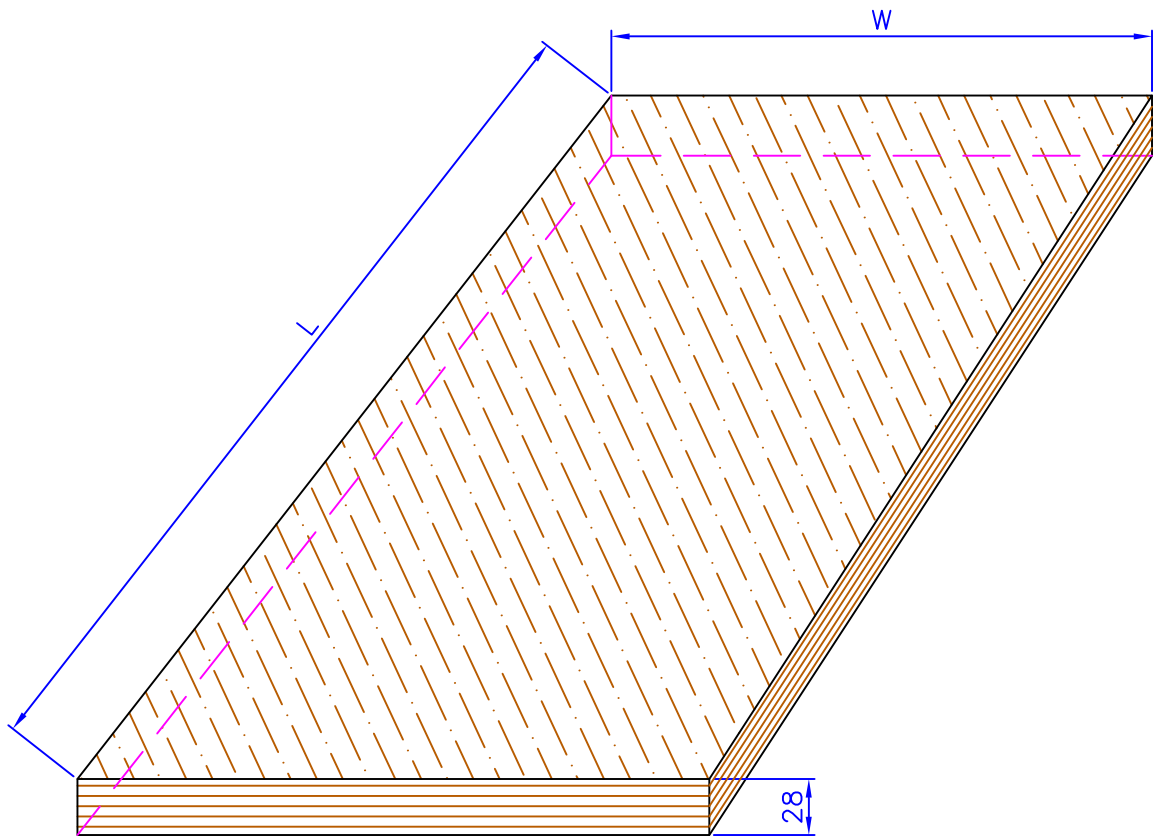

Free chamfer service is available upon request

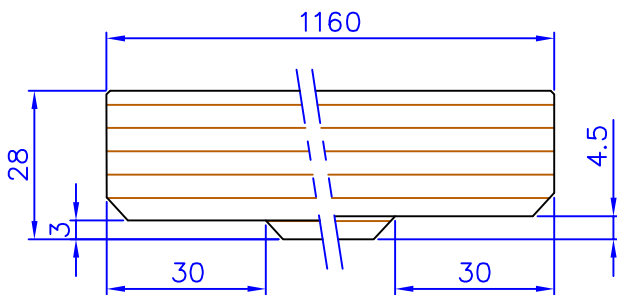

GRADE	PART NO.	SIZE	Breaking Load (kgs)
Grade H	CIMC-D32-02A-GH	28X1160X2400	7260
Grade AA	CIMC-D32-02A-GAA		6500
Grade AB	CIMC-D32-02A-GAB		6000
Grade B	CIMC-D32-02A-GB		5460

TITLE	Wooden Flooring 木地板	WEIGHT	KGS		
SPEC		MATERIAL			
PART NO.	CIMC-D32-02	UNIT	mm	PAGE NO.	61

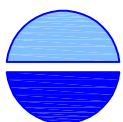

CIMC

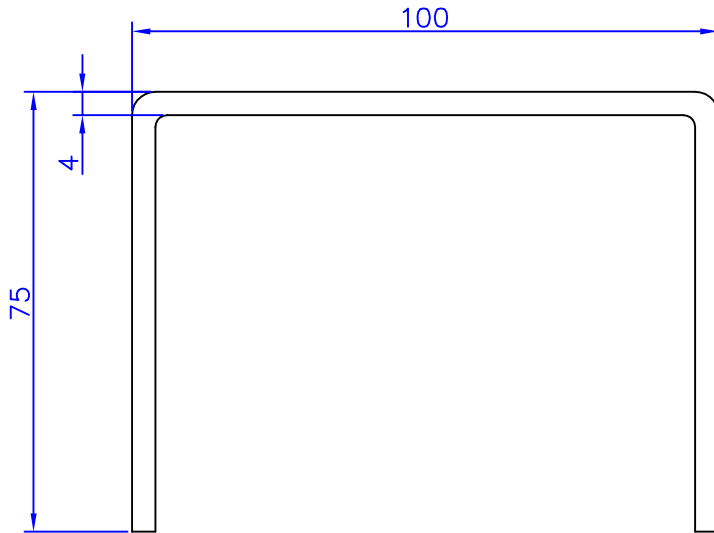

PART NO.	SPEC	L	WEIGHT
CIMC-D33-01A	4.0X75X100X75X2268	2268	16.664
CIMC-D33-01B	4.0X75X100X75X2328	2328	17.105

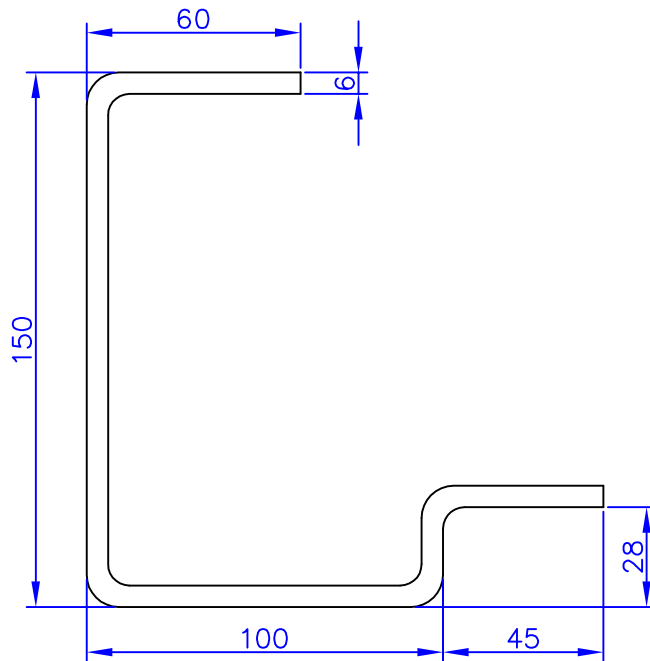

L=2328

PART NO.	SPEC	WEIGHT
CIMC-D33-01C	6.0X100X150X60X2328	38.048

TITLE	Gooseneck Cross Rail 鹅颈槽主横梁	WEIGHT	KGS
SPEC		MATERIAL	CORTEN
PART NO.	CIMC-D33-01A/B/C	UNIT	mm
		PAGE NO.	62

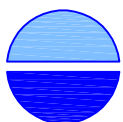

CIMC

Gooseneck Side Rail 鹅颈槽侧梁



L=3305

PART NO.	SPEC	WEIGHT
CIMC-D33-02	6.0X146X65X3305	28.487

Gooseneck Bottom Rail 鹅颈槽背梁

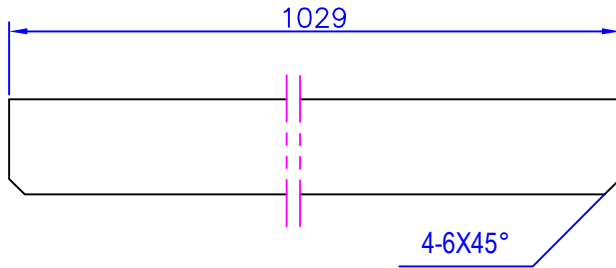

L=1029

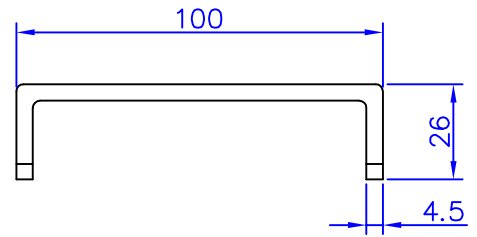

PART NO.	SPEC	WEIGHT
CIMC-D33-03	4.5X26X100X26X1029	4.871

Gooseneck Plate 鹅颈槽板

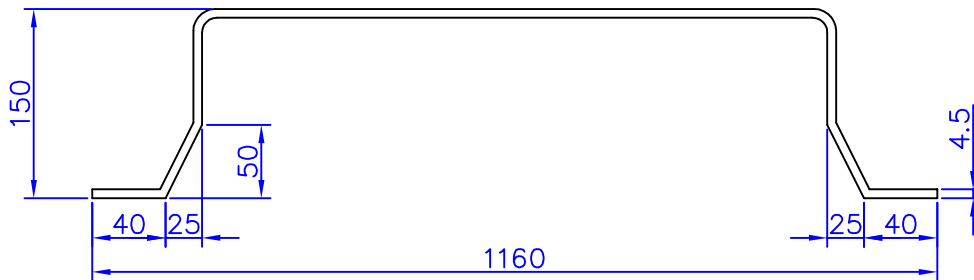

L=3307

PART NO.	SPEC	WEIGHT
CIMC-D33-04	4.5X150X1160X150X3307	161.942

TITLE	Gooseneck Rail Accessary 鹅颈槽系列	WEIGHT	KGS
SPEC		MATERIAL	CORTEN
PART NO.	CIMC-D33-02/03/04	UNIT	mm
		PAGE NO.	63

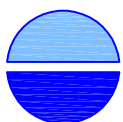

CIMC



CIMC-D36-01



CIMC-D36-01-3



CIMC-D36-01-1



CIMC-D36-01-4



CIMC-D36-01-2



CIMC-D36-02

PART NO.	NAME	SPEC
CIMC-D36-01	双头钻 Double End Tapping Screw Bit	Phillips Head
CIMC-D36-01-1	单头钻 Simple End Tapping Screw Bit	Phillips Head
CIMC-D36-01-2	单头钻 Simple End Tapping Screw Bit	Trox Head
CIMC-D36-01-3	套筒 Socket	M12.5X12.5
CIMC-D36-01-4	套筒 Socket	M19X19
CIMC-D36-02	扩孔器 Redrill Bit	

TITLE	Tapping Screw Bit 钻头、套筒	WEIGHT	KGS		
SPEC		MATERIAL			
PART NO.	CIMC-D36-01	UNIT	mm	PAGE NO.	64

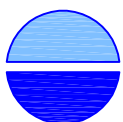

CIMC



CIMC-D36-05



CIMC-D36-06-1



CIMC-D36-06-2

PART NO.	NAME	WEIGHT
CIMC-D36-05	磁力线 Magnetic Measuring lines	0.1
CIMC-D36-06-1	验箱尺 Measuring Ruler	0.03
CIMC-D36-06-2	验箱锤 Hammer for inspection	0.3

TITLE	Container Inspection Tool 集装箱验箱工具	WEIGHT	KGS		
SPEC	Set	MATERIAL			
PART NO.	CIMC-D36-05/06	UNIT	mm	PAGE NO.	65

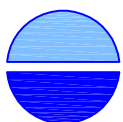

CIMC

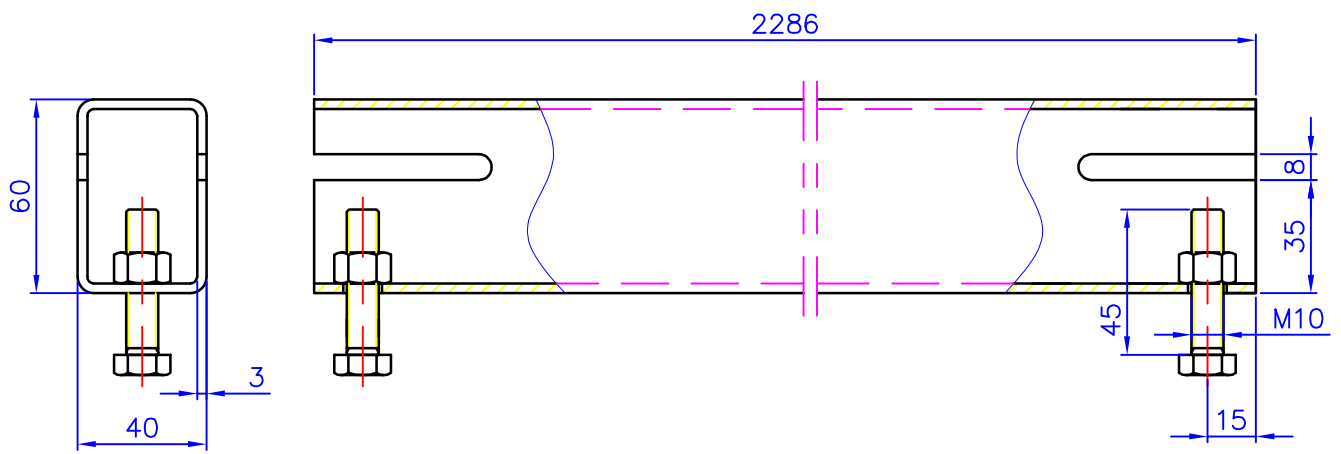

Finish: Hot Dip Galvanized, Min Thickness:75um.

TITLE	Garment Hanger Bar 挂衣架	WEIGHT	11.000 KGS		
SPEC	L=2286mm	MATERIAL	Q235		
PART NO.	CIMC-D37-01	UNIT	mm	PAGE NO.	66

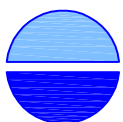

CIMC

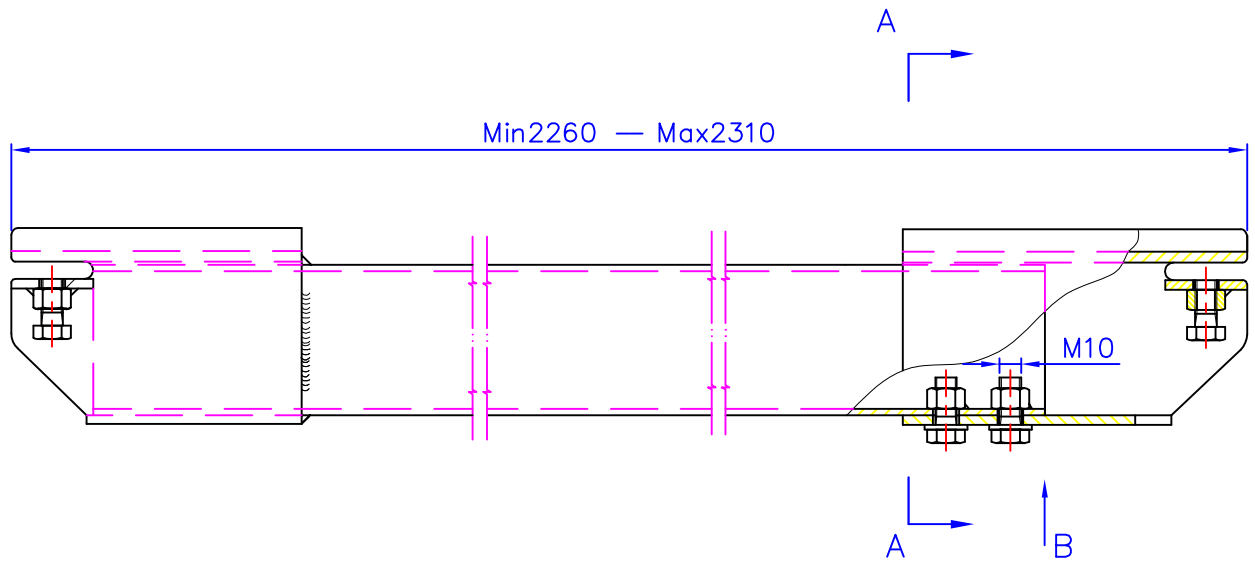

A-A

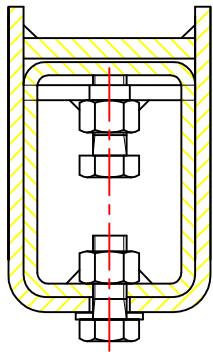

B向

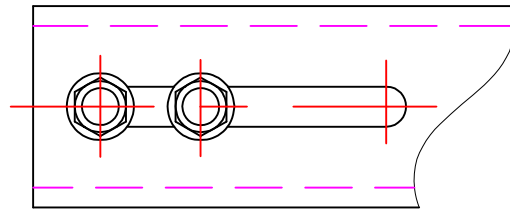

TITLE	Garment Hanger Bar 挂衣架	WEIGHT	16.000 KGS		
SPEC		MATERIAL	Q235		
PART NO.	CIMC-D37-02	UNIT	mm	PAGE NO.	67

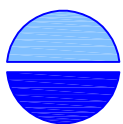

CIMC

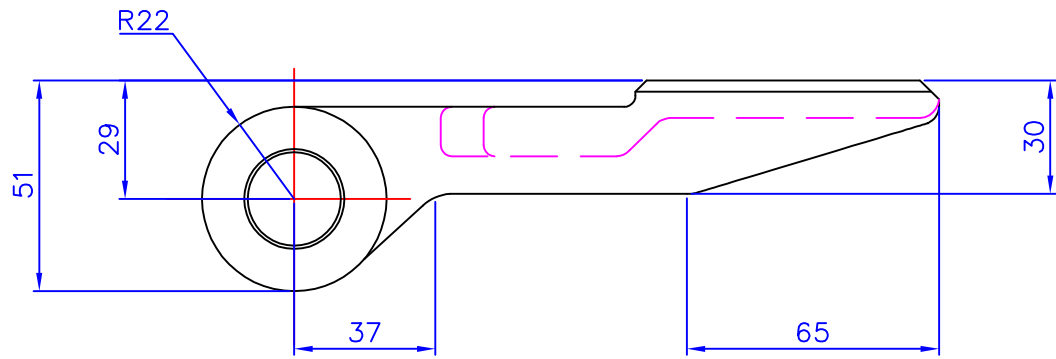
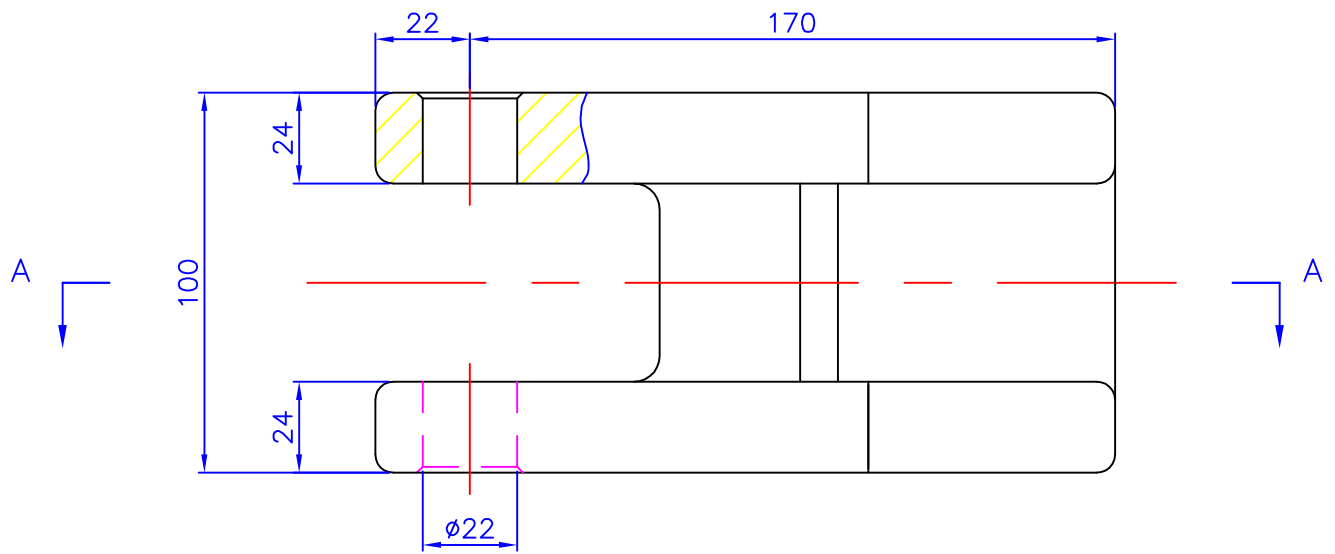

A-A

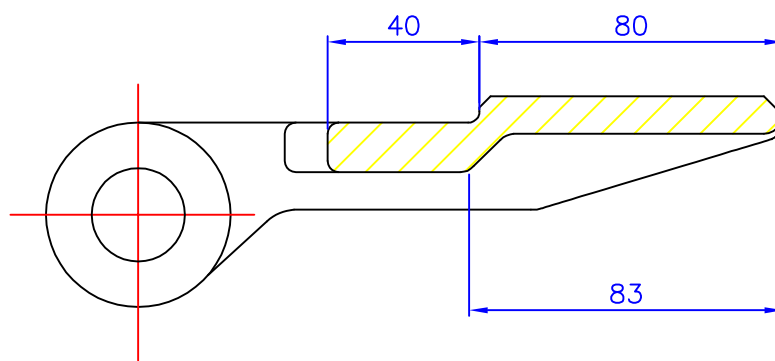

TITLE	Hing Blade,Open Top 开顶箱铰链板	WEIGHT	3.500 KGS		
SPEC		MATERIAL			
PART NO.	CIMC-K01-05	UNIT	mm	PAGE NO.	68

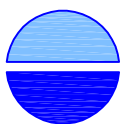

CIMC

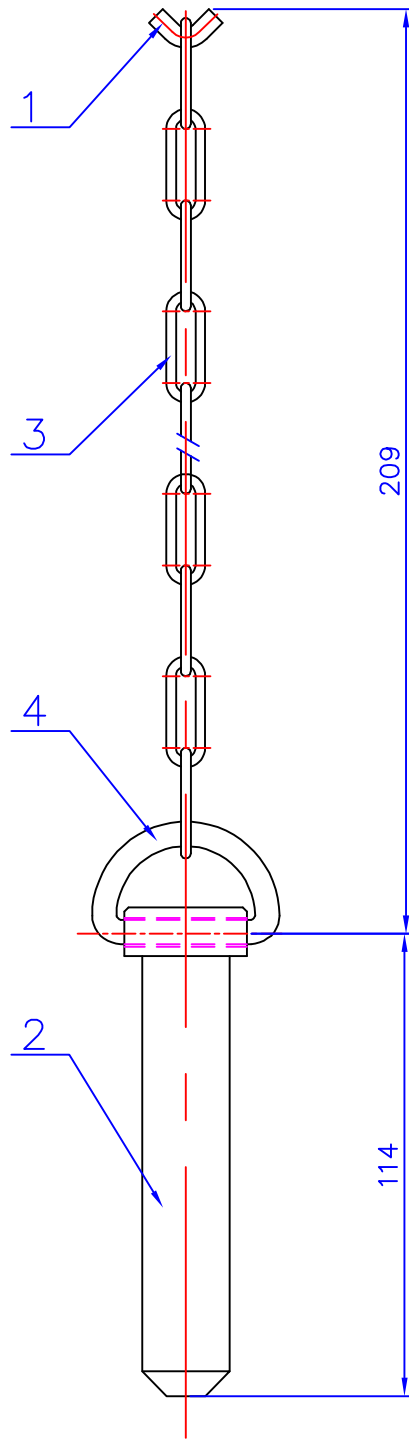

REF. NO.	DESCRIPTION	DRG.NO.	PCS
1	Staple For Locking Pin	R47300-0009-01	1
2	Locking Pin	R47300-0009-02	1
3	Chain	R47300-0009-03	X
4	Chain End Ring	R47300-0009-04	1

TITLE	Hing Pin with Chain 开顶箱铰链销（带链条）	WEIGHT	KGS		
SPEC		MATERIAL	SS400		
PART NO.	CIMC-K01-06-1	UNIT	mm	PAGE NO.	69

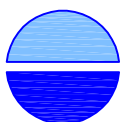

CIMC

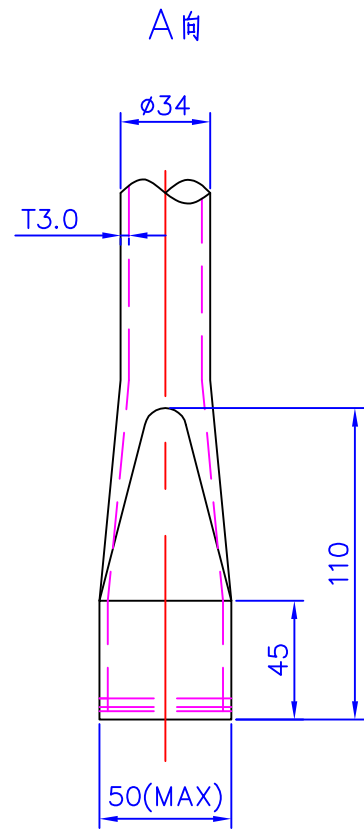
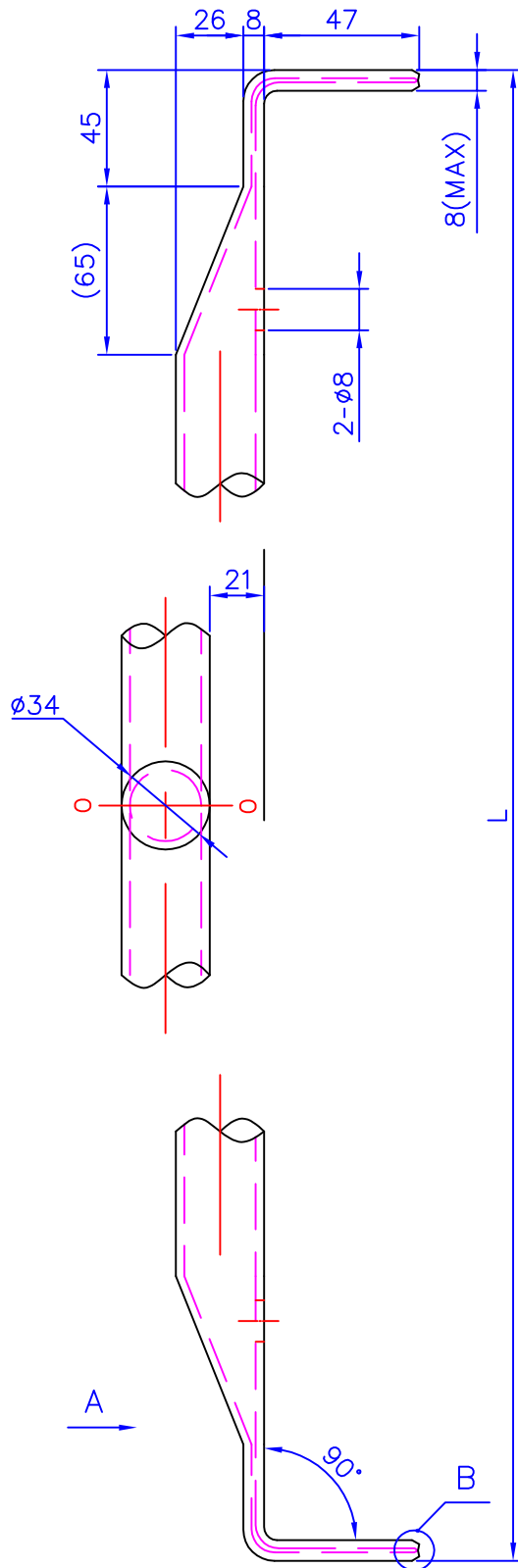

DETAIL B
3:1

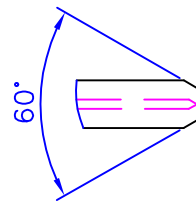

PART NO.	SPEC	WEIGHT
CIMC-K03-01	T=3.0 L=2260	5.8
CIMC-K03-02	T=3.0 L=2325	6.2

TITLE	Roof Bow 开顶箱加强筋	WEIGHT	KGS
SPEC	T=3.0 L=2260/2325	MATERIAL	Q235B
PART NO.	CIMC-K03-01/02	UNIT	mm
		PAGE NO.	70

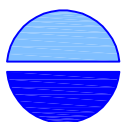

CIMC